

Lecture 3 - ENV 402

Water Supply from Source to Consumer

Marisa Boller

EPFL, 25 September 2025

Eawag-Sandec



Community water collection point in Uganda

Source: Boller 2023

A little about me

Education: BSc & MSc Environmental Engineering (EPFL)

Eawag / Sandec: Project Manager, Water Supply and Treatment (Feb. 2023 – present)

Interests: Drinking water safety in rural communities and small towns, treatment innovation... just WASH+SWM in general



Motivation: Addressing inequalities in access to safe water

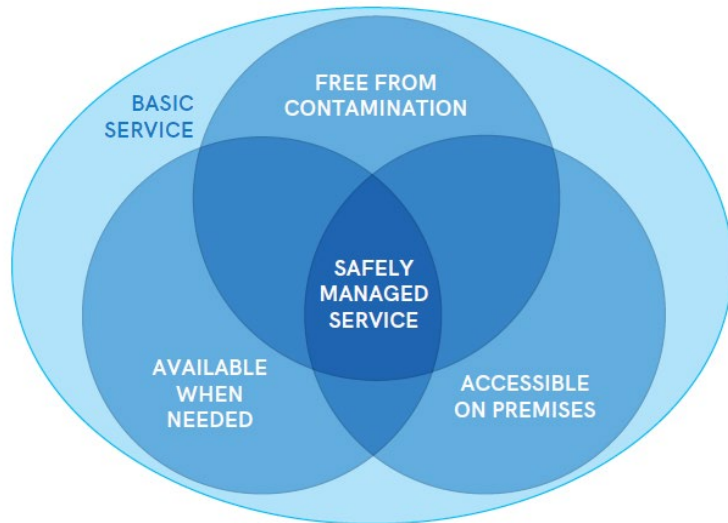

Learning objectives

By the end of the class, you'll be able to:

1. Understand the objectives and structure of the **Water Compendium**
2. Recognize the six functional groups from source to consumer
3. Describe the advantages and drawbacks of (a selection) of water supply technologies
4. Illustrate a system template for a 'real world' scenario

Lecture

Part 1	Technology overview <ul style="list-style-type: none">• Introduction to the Water Compendium• Functional groups• Schematic presentation• Applicability, operation and environmental aspects
	15 min break
Part 2	Water system design <ul style="list-style-type: none">• System templates• Design tradeoffs and local applicability• Group exercise
	Discussion

Part 1

Technology Overview

Learning objective 1:

Understand the objectives and structure of the Water Compendium

Learning objective 2:

Recognize the six functional groups from source to consumer



How to choose an appropriate drinking water supply system?



Important considerations:

- Source water quality and quantity
- Locally available skills and resources to operate and maintain
- Cultural preferences
- Space availability
- Source of energy
- Environmental impacts

How to choose an appropriate drinking water supply system?

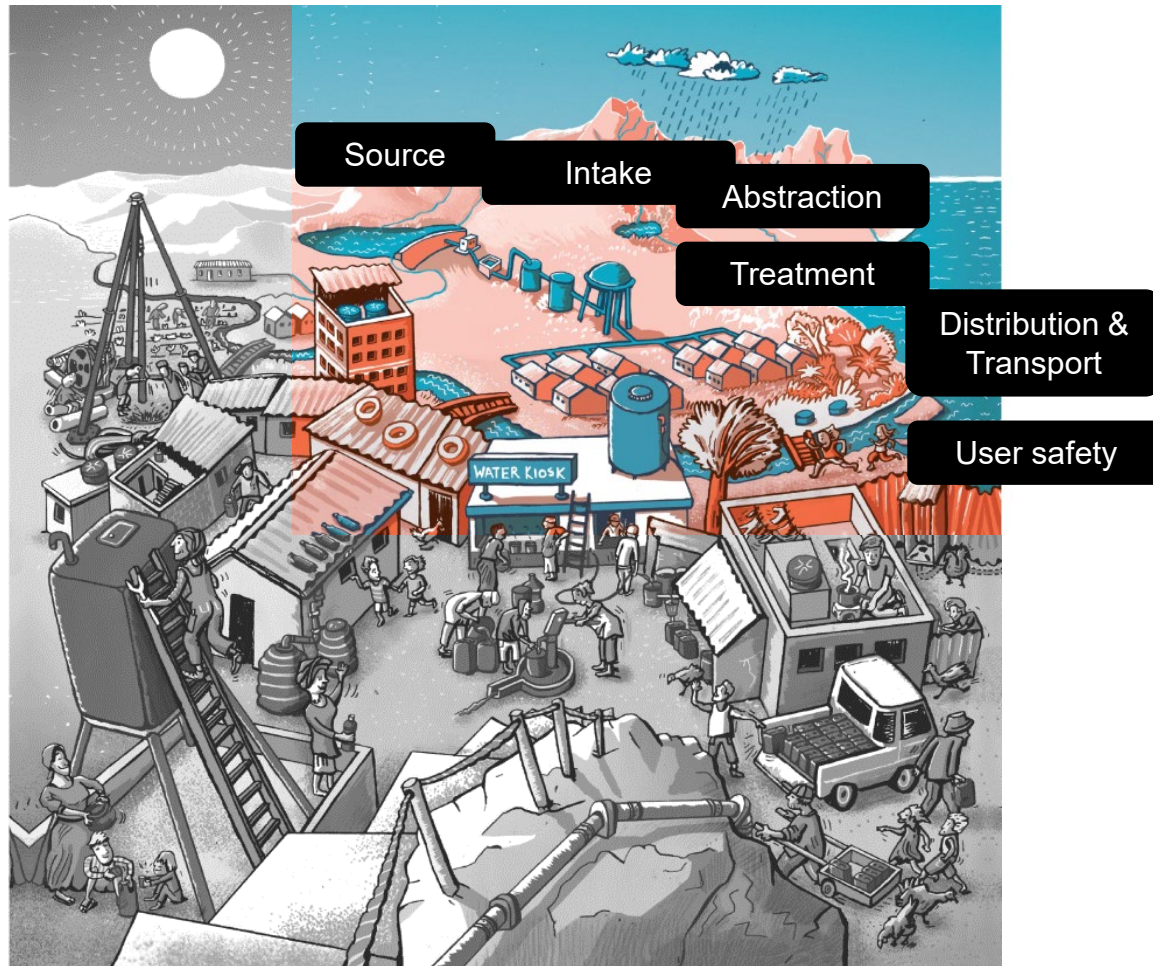

Centralized drinking water supply systems

How to choose an appropriate drinking water supply system?

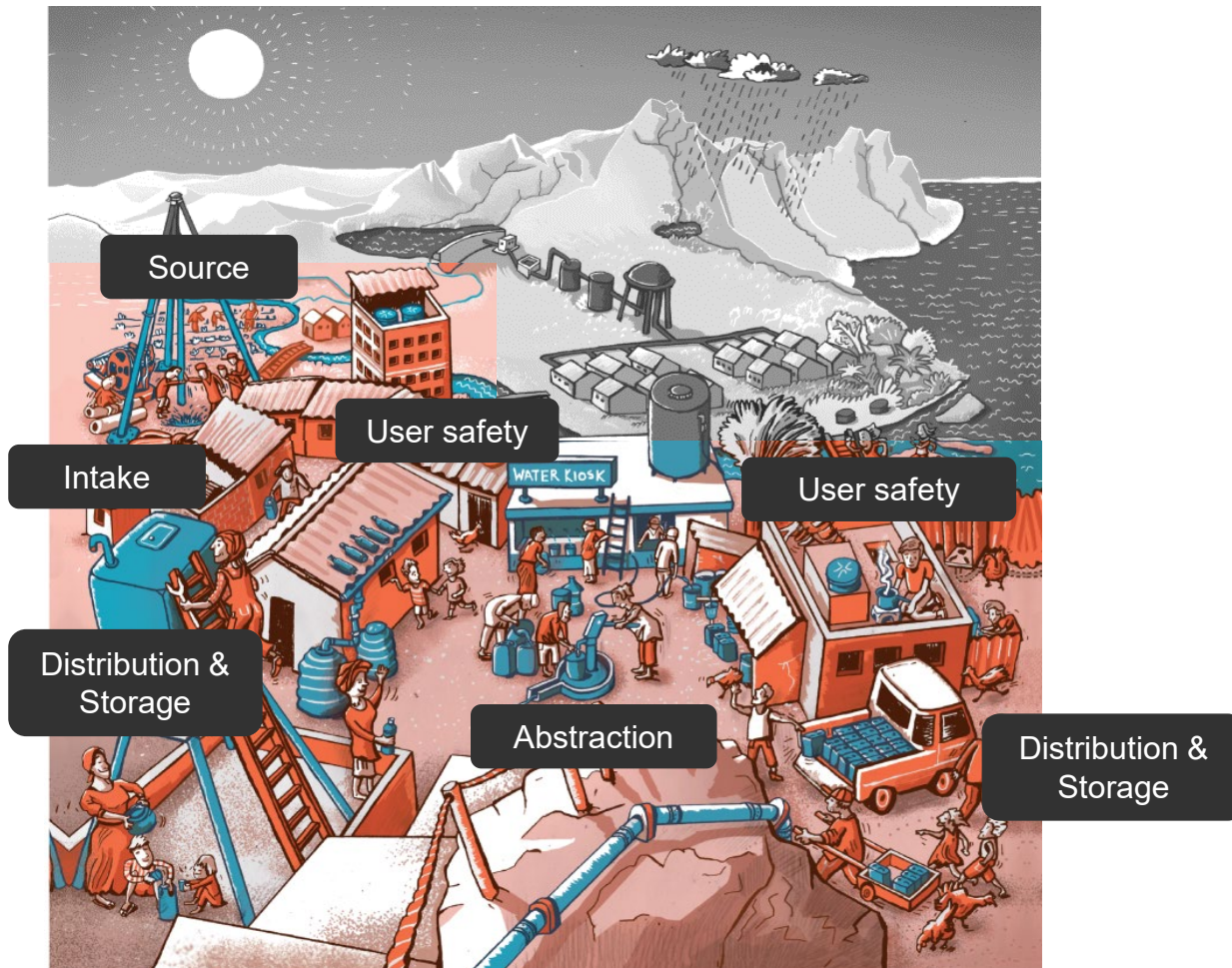

Decentralized drinking water supply systems

Objectives of the Water Compendium

→ Huge number of great publications on water supply

- Concise and well structured overview of all technological steps from source exploitation to household water treatment and storage
- The whole range of rural, peri-urban and urban technologies (focus on the low and middle income setting)
- Issues of risk management and long term water safety, monitoring, financial and institutional aspects

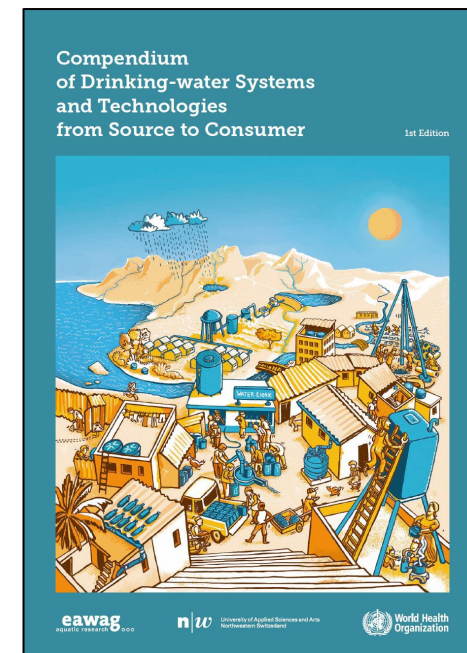

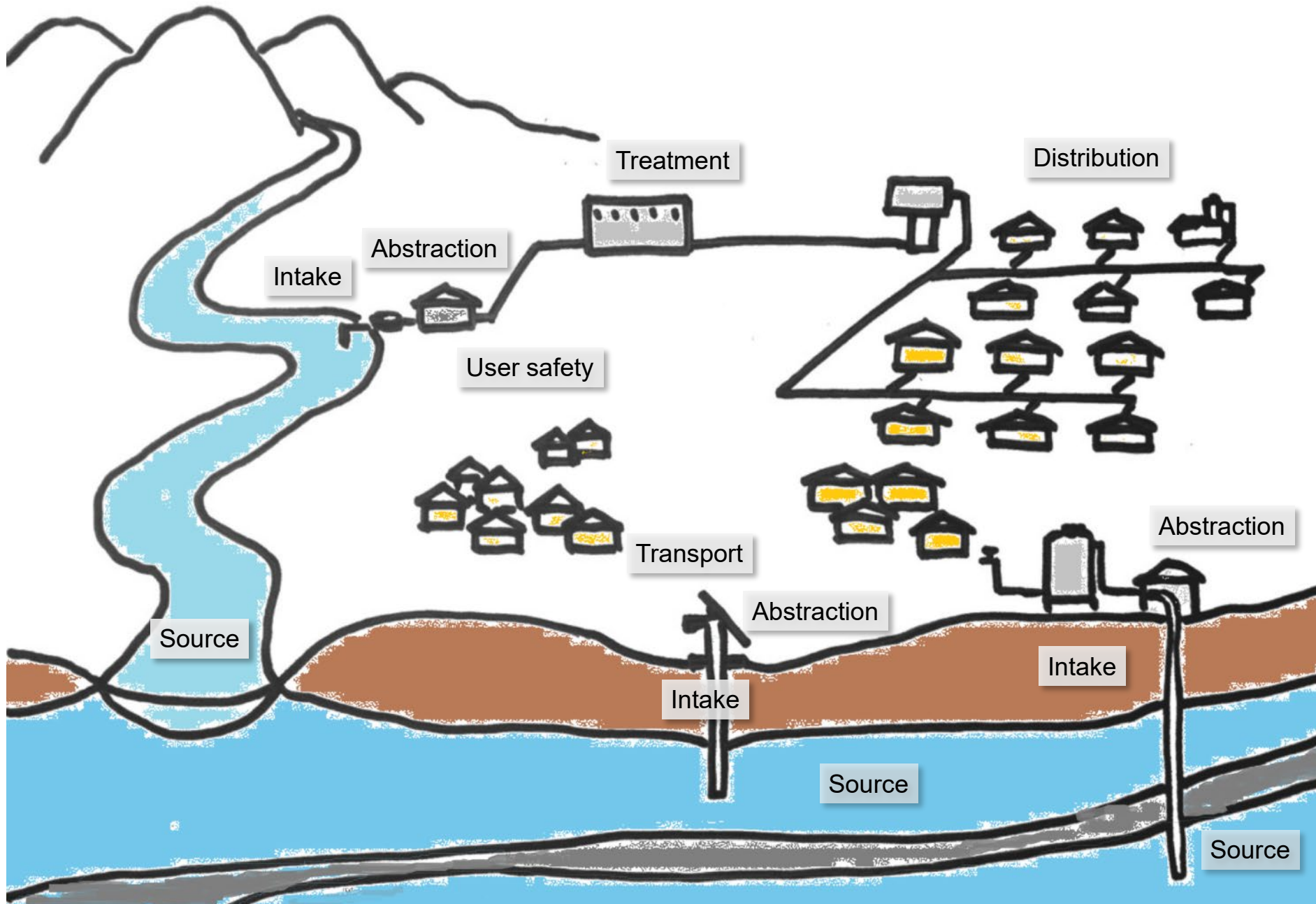

Functional groups: Technological steps from source to consumer

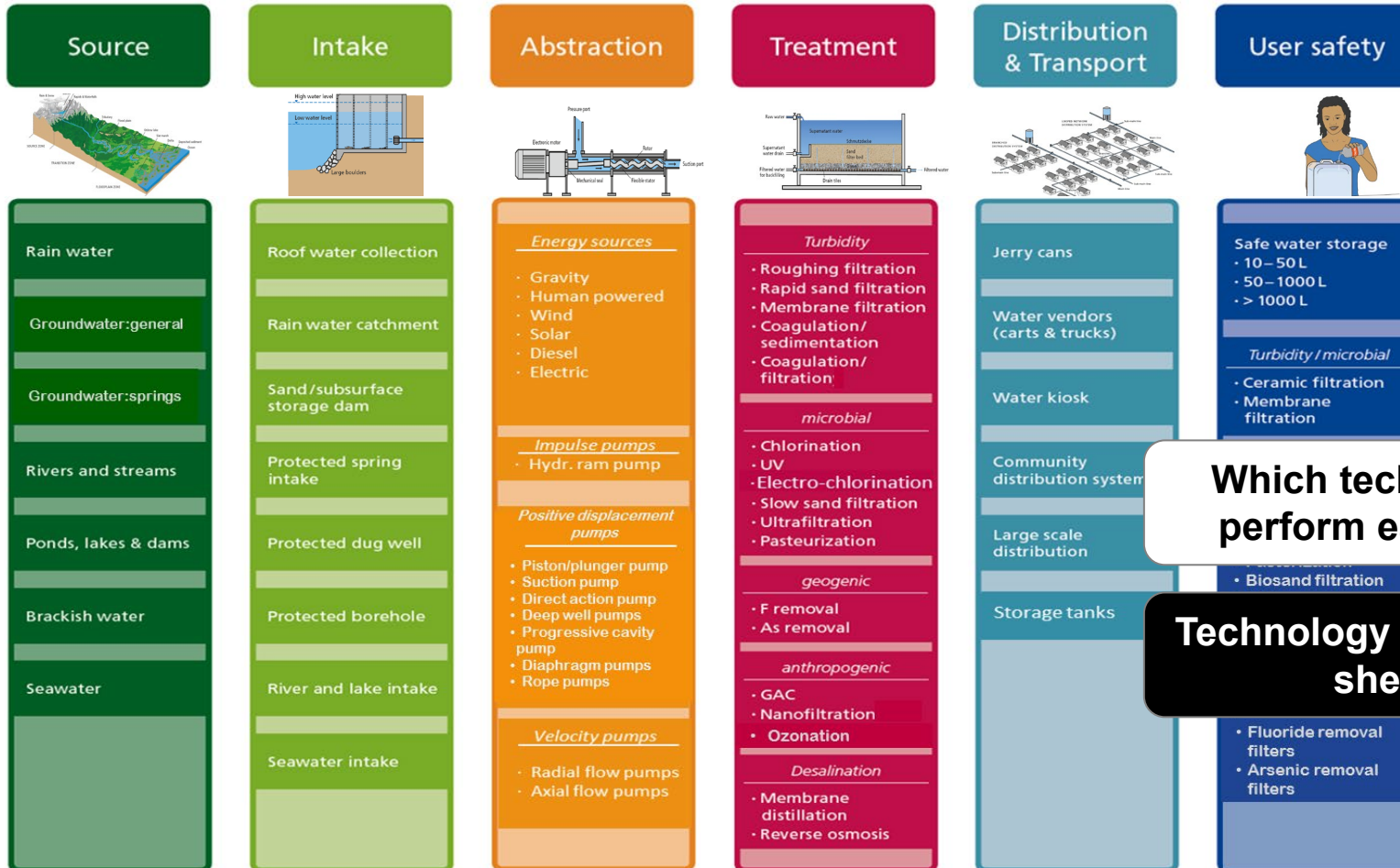

Which technologies perform each role?

Technology information sheets

Technology information sheets

Source

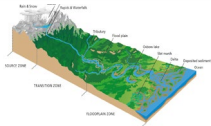

- Rain water
- Groundwater:general
- Groundwater:springs
- Rivers and streams
- Ponds, lakes & dams
- Brackish water
- Seawater

S. SOURCE

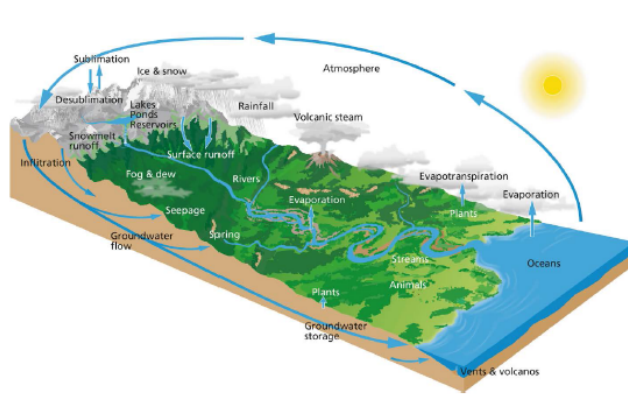

To establish a water supply system, a water resource providing sufficient quantity of water should be available. Commonly, water supplies base on groundwater or surface water resources. In some areas rainwater can also be a safe water resource. Water resources usually contain dissolved or particulate matter and gases as a result of interaction with atmosphere, minerals in rocks, natural organic matter, macro- and microorganism. Anthropogenic activities further impact the quality of

these water resources but it does not mean it is contaminated with pathogenic microorganisms. In some regions it can be also affected by chemical contamination such as fluoride, arsenic or high salinity as well as iron and manganese. Localizing groundwater abstraction sites and estimating available groundwater quantities is a complex task which requires drilling and pumping equipment for abstraction (see chapter 'Abstraction').

This section describes water resources which can be used for drinking water supply.

S.1. Rainwater

S.2. Groundwater

S.3. Spring water

S.4. River and stream water

39 Compendium
Drinking Water Systems and Technologies from Source to Consumer

S.5. Ponds, lakes and dams

S.6. Brackish water, seawater

Surface water sources such as rivers and streams (S.4) or ponds, lakes and dams (S.5) are easily accessible. Generally, surface water can be considered microbially contaminated and might be turbid ('muddy'). Thus, it requires treatment before consumption. Groundwater (S.2. – S.3.), the water below the surface, is generally better protected from contamination with pathogenic microorganisms. In some regions it can be also affected by chemical contamination such as fluoride, arsenic or high salinity as well as iron and manganese. Localizing groundwater abstraction sites and estimating available groundwater quantities is a complex task which requires drilling and pumping equipment for abstraction (see chapter 'Abstraction').

Rainwater (S.1.) is generally used as supplementary source of water, which often requires storage tanks. Brackish and seawater (S.6.), water resources with high salt contents, are alternative water sources in water scarce areas requiring de-salination before consumption. Usually they are only used when other water sources are not available or access is limited.

Water is needed to carry out activities other than drinking or cooking and particularly in water scarce areas communities often do not differentiate between water for domestic and non-domestic uses. Thus, the water supply systems in water scarce areas or areas with extended droughts are designed with multiple water supply systems are designed to impact and avoid competition within the community.

When selecting any kind of water resource, an initial assessment should be conducted which considers the following factors:

- *Water quantity:* is the yield sufficient during the entire year? Can changes in water

availability and water demand be estimated?

- *Water quality:* How is water quality affected by agriculture, sanitation practices or point contamination sources in communities?
- *Technology required for exploitation:* Which technologies are required for abstraction and treatment and are those feasible? Are there both skills and technology available for water resource exploitation? Are the costs of water resource exploitation affordable?
- *Energy:* Is pumping needed or can gravity be used?

Criteria for selection

What are legal and social constraints for the resource, are there any specific requirements for certain resources?

- *Environmental and health risks:* What is the impact of source exploitation on population, environment and ecosystem in its catchment?

Background info

Technology information sheets

Applicable to systems:
Management level:

T.2.4. Ultrafiltration

Local availability of technology or components:

Management level: Community, centralized

Technology maturity level:

Available in most transition countries on regional level, otherwise imported membrane modules
Established technology

2,3,7,8

Community, centralized

Available in most middle income countries, otherwise imported membrane modules

Established technology

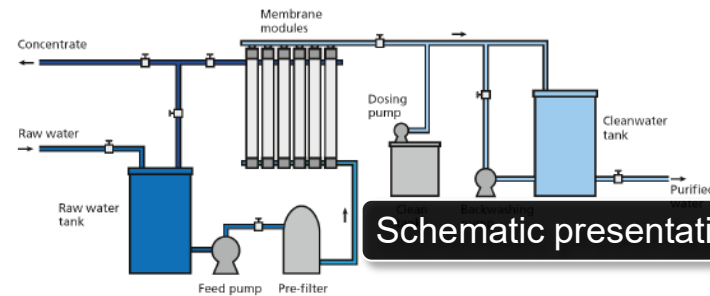

Schematic presentation/drawing

Operational issues & functionality

Ultrafiltration is used to retain bacteria, protozoa and most viruses as well as particles and some organic matter. The pressure difference between inflow (feed) and filtrate (permeate) drives the

Membranes are classified by their pore size. For the removal of turbidity, larger particles, protozoa, bacteria and part of viruses, ultrafiltration (UF) membranes can be applied. UF membranes have pore sizes of about 0.01-0.1 µm. All particles with a larger diameter than the pore size are retained by the membrane. Often UF membranes are classified by membrane cut-off values in Dalton, which is the ability of membranes to retain certain organic polymers of a defined size (e.g. dextrane).

The retained particles and microbes accumulate on the membrane surface or in the membrane pores, forming a cake layer. Smaller particles and dissolved organic matter can penetrate into the membrane pores and adsorb there. Both processes reduces the flow of water through the membrane when operated

under constant pressure. Or they lead to increase of transmembrane pressure when systems are operated using constant flow. The formation of the cake layer and deposition of organic matter within the pores of the membrane is called membrane fouling. Therefore, systems need a periodical cleaning by physical and/or chemical treatment (see operation and maintenance).

Most commercial UF membranes are polymeric. Three major types of membrane modules are used: hollow fiber modules, spiral wound modules and flat sheet membrane modules. In drinking water production mostly hollow fiber modules are used, since they are most compact, low cost and have lower energy consumption compared to other module configurations.

Dense UF membranes show high retention of bacteria and protozoa (also cysts) of 99.9-99.9999% (3-6 LRV). Removal of viruses vary between LRV 1 and 5 depending on the membrane pore size (cut-off). Compared to the MF membranes, UF membranes show the same removal of turbidity and suspended solids, and better removal of organic matter. However,

The typical design of an UF system includes feed pump creating pressure to filter water through a series of membrane modules placed in racks and connected in parallel. Water is pumped in a "dead-end mode" implying that all inlet water passes through the membrane. "Cross-flow" systems exist as well but are characterized by lower recovery and high energy demand values and used rarely. The systems are designed in a modular way and the capacity of the system can be easily adapted to the needs.

Applicability and adequacy

Ultrafiltration is an advanced and reliable process suitable for the removal of microbial contamination. However, it requires a high degree of automation and process control needed to control the pumps, dosing and return performance. Due to small footprint and low energy consumption, UF is more suitable than alternative systems and some level of expertise either provided by the operator or supplier is required for maintenance of the systems. Some gravity-driven UF systems for applications at a small scale in community water supplies exist on the market.

When selecting a membrane system for disinfection one should pay special attention to virus removal. MS2 (~0.02 µm) or phi X174 (~0.03 µm) as common model viruses used for membrane testing (due to their small size) should be retained to at least 99.9% (3 LRV). Otherwise an additional disinfection step like chlorination (T.2.1) or UV treatment (T.2.2) is required.

Operation and Maintenance

Depending on quality of raw water, the membranes might be done when irreversible fouling occurs and the systems have to be operated at higher pressure or

Health and environmental aspects/Acceptance

Retentate disposal must be carefully considered, since it contains high concentration of organic matter. Disinfection byproducts are not formed during UF. Disinfection byproducts are not formed during UF. Disinfection byproducts are not formed during UF. Disinfection byproducts are not formed during UF.

Health & environmental aspects/ Acceptance

Advantages and disadvantages

- + effective removal of turbidity
- + providing a barrier to bacteria, protozoan cysts
- + consistent and reliable operation through automation and ability to treat water of variable quality

Advantages & disadvantages

- + transportable and mobile membrane units using smaller land area for the treatment plant in comparison with conventional filtration systems
- + gravity-driven systems exist
- relatively high investment costs, considerable operational and maintenance costs
- skilled personnel required
- continuous operation is recommended to guarantee optimal membrane performance, therefore reliable energy supply is needed
- no residual disinfectant (safe distribution and storage must be assured otherwise)

Operation & maintenance

Functional groups: Technological steps from source to consumer

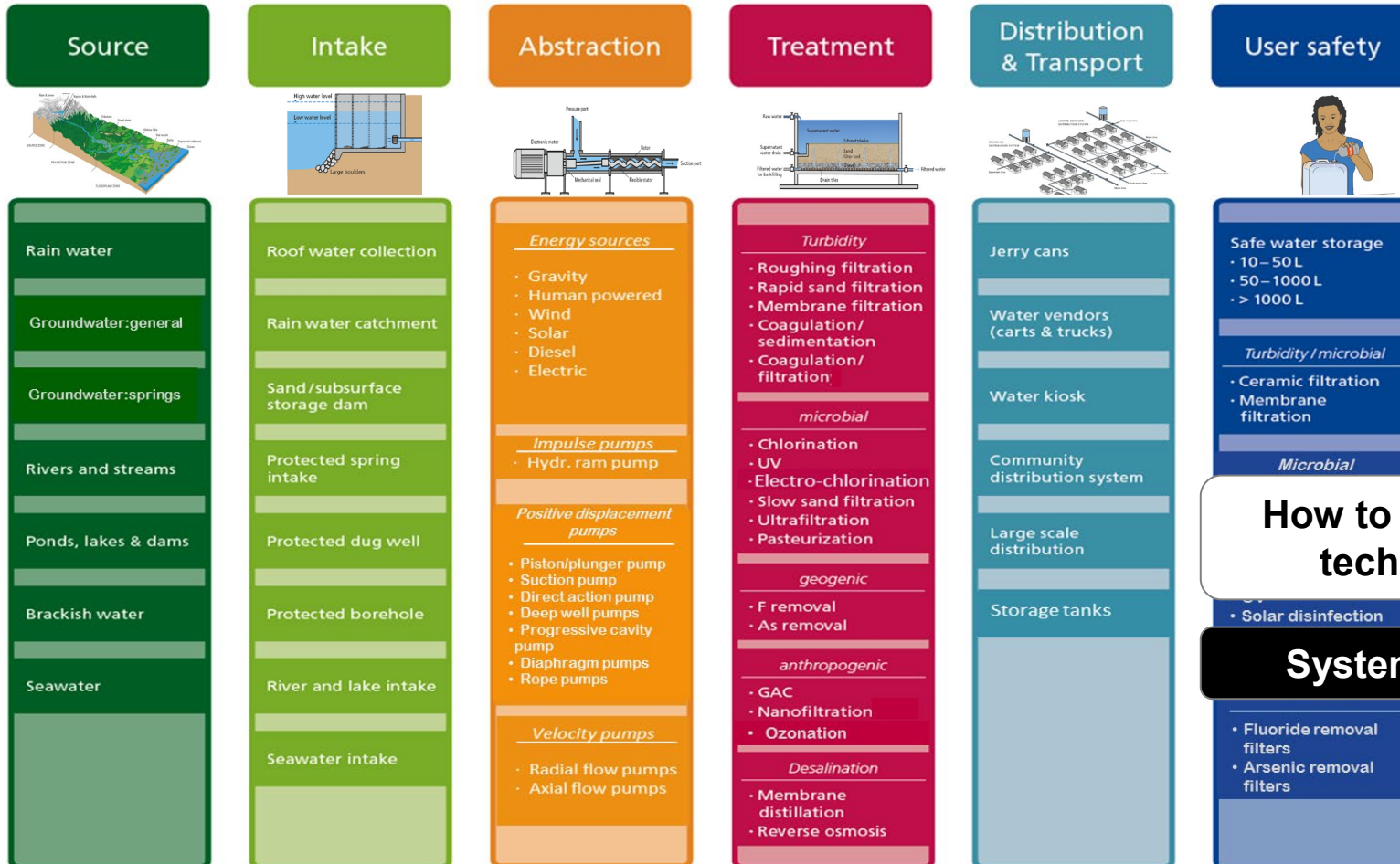

How to combine/link technologies?

System templates

System templates

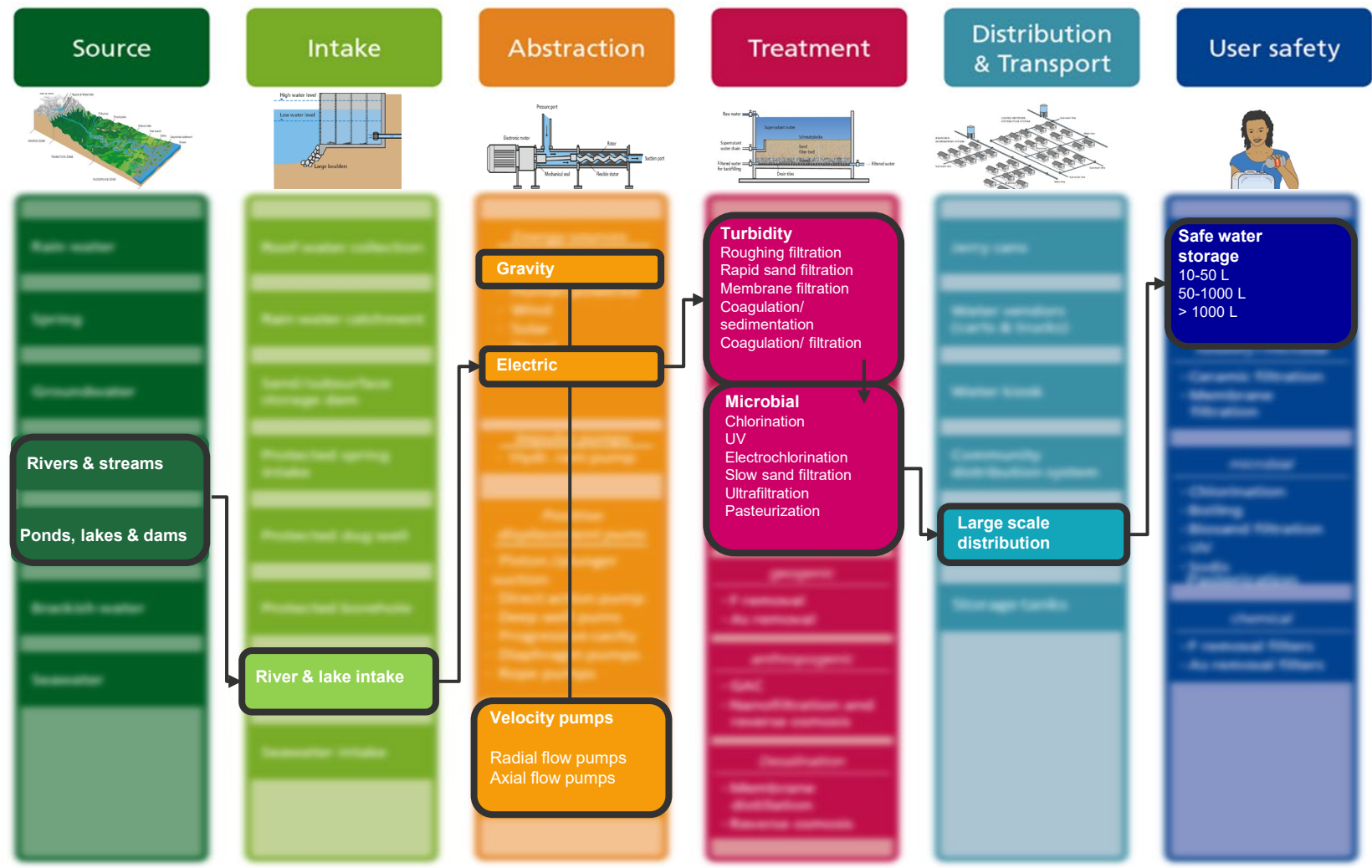

System templates

System 1: Rainwater harvesting

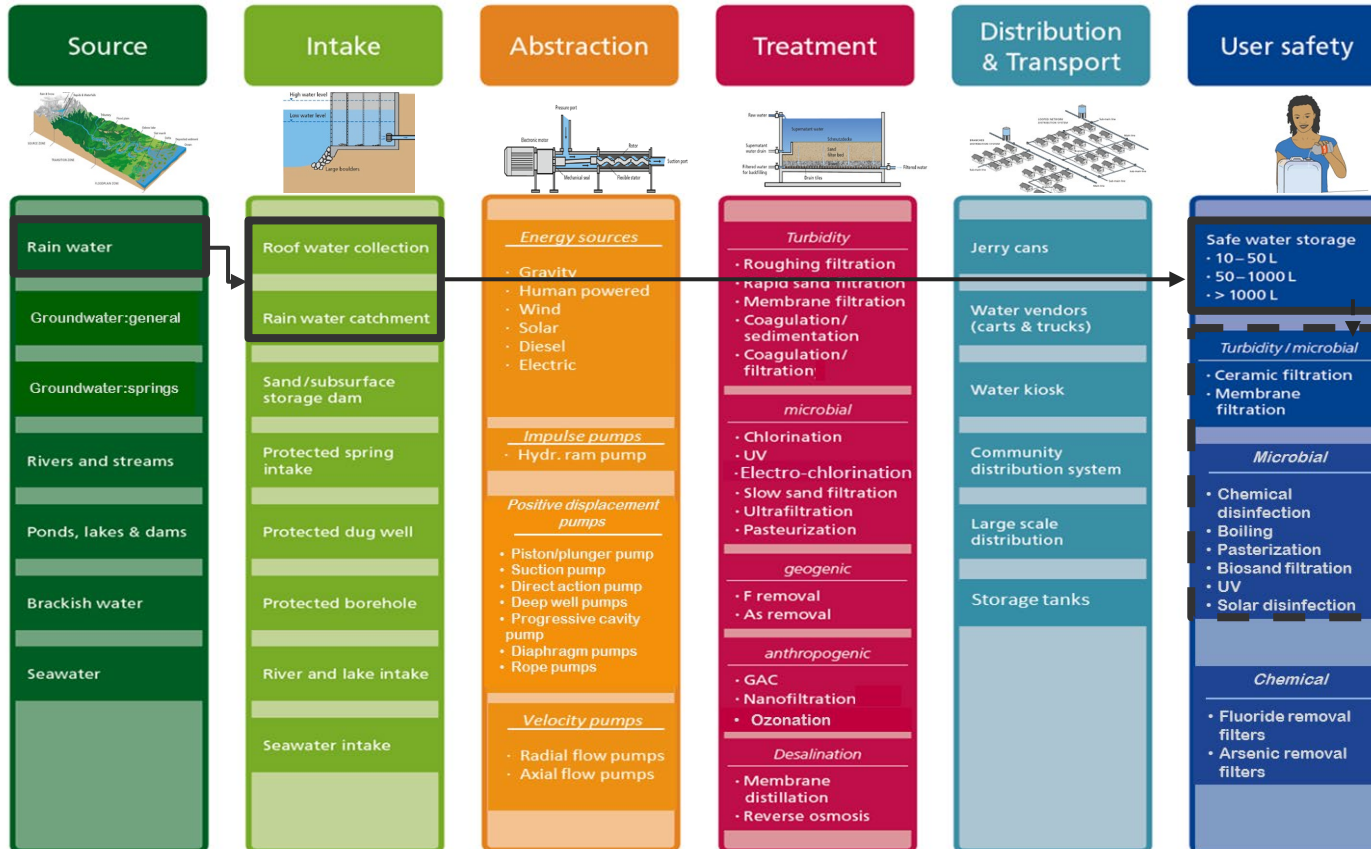

System 1: Rainwater harvesting

This system can be used as a major source of water supply where there is sufficient rainfall and storage capacity or seasonally to complement other water sources.

Rainwater (S.1) is collected through a roof water

Design parameters

timber or metal sheets. It is fixed with hooks below the roof and catches water falling from the roof. An uneven slope of the guttering should be avoided because of formation of stagnant water pools leading to mosquito-breeding.

Source

The roof runoff (I.1) should optimally have a first flush system (I.1.1) to redirect and discharge the first portion of rainwater from the roof which is likely to be more heavily contaminated. The capacity of the first flush system should be designed relative to the size of the roof catchment area. The flushed water should be redirected away from the collection area (e.g. via a pit or drainage channel) and should not be used for collection. Some configurations may include a filter upstream of the first flush mechanism which consists of a coarse filter that protects against larger pieces of debris from entering the system. In some cases rainwater is collected first into a settling tank and after redirected into storage tanks or into the ground to collect. The capacity of the storage tanks should be sufficient to accommodate enough water to cover the needs of users for the defined period of time without rain.

Intake system

The main design parameters of a roof water collection system are the roof area, the rainfall intensity and pattern and the water demand. The amount of rain water harvested at a given time of the year can be estimated by using the following equation:

$$Supply (m^3) = Rainfall (mm/year) \cdot Roof Area (m^2) \cdot Run-off coefficient$$

A roof run-off coefficient is the ratio of the volume of rain water that runs off the surface to the volume of rainwater that falls on that surface (varies between 0.5 - 0.9). A run-off coefficient of 0.9 means that 90% of the rainfall is collected. It considers water losses due to spilling, evaporation, wind, overflowing gutters, and leaky collection pipes and first-flush devices.

The size of the storage tank is a function of the supply and demand of water throughout the dry period including unplanned use or use for other needs and availability of alternative sources.

Considerations

This system is applicable as a major source of water throughout only part of the year when rain intensity allows collection of sufficient volumes of rain water. The material and the size of the roof directly influence the amount of water collected and its quality. Reasonably good quality rain water can be collected from roofs out

Considerations regarding applicability

Although rain water quality is usually good, contamination of the roof and storage tanks may lead to a deterioration in water quality (e.g. from animal activity, vegetation or aerial deposition from local contaminating activities, such as crop spraying or land burning). Therefore roof catchments as well as gutters and tanks should be cleaned regularly to remove dust, leaves and animal excrement. Although the first flush mechanism can additionally reduce the concentration of contaminants entering the storage tank, stored rainwater (U.1) should ideally be disinfected prior to consumption where there is a risk of microbial contamination, either by disinfection of the tank, or via household water treatment (U.User Safety).

Structure of the Compendium

Part 1. System templates

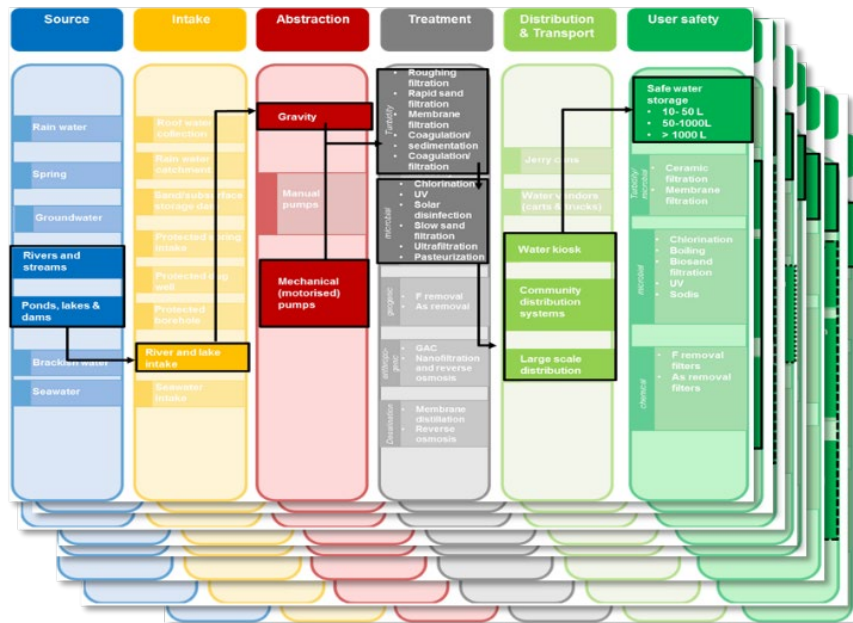

- System 1** Rainwater harvesting
- System 2** Surface water treatment centralized
- System 3** Surface water treatment decentralized
- System 4** All fresh water sources: manual transport with household water treatment
- System 5** Gravity flow supplies
- System 6** High quality groundwater
- System 7** Decentralized groundwater treatment with geogenic contamination
- System 8** All fresh water sources with anthropogenic contamination
- System 9** Desalination of brackish and salt water

Part 2. Technology information sheets

Part 3. Cross-cutting issues

Optional viewing

Water Supplies (10') <https://youtu.be/NDYFVgH4O3A>

Maryna Peter introduces the 6 **functional groups** of a water supply system (source, intake, abstraction, treatment, distribution & transport and user safety), a combination of which can be applied to any water supply. However, all solutions have to be adapted to the **local context**.

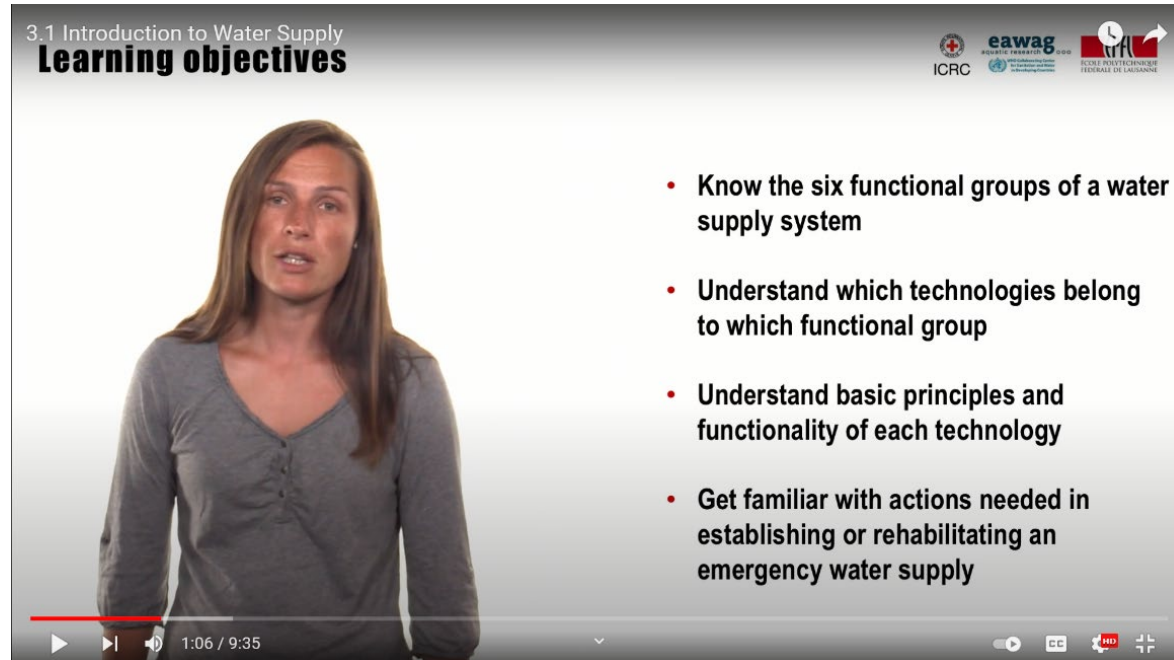

3.1 Introduction to Water Supply
Learning objectives

ICRC eawag EPFL

- Know the six functional groups of a water supply system
- Understand which technologies belong to which functional group
- Understand basic principles and functionality of each technology
- Get familiar with actions needed in establishing or rehabilitating an emergency water supply

1:06 / 9:35

Learning objective 3:

Describe the advantages and drawbacks of (a selection) of water supply technologies

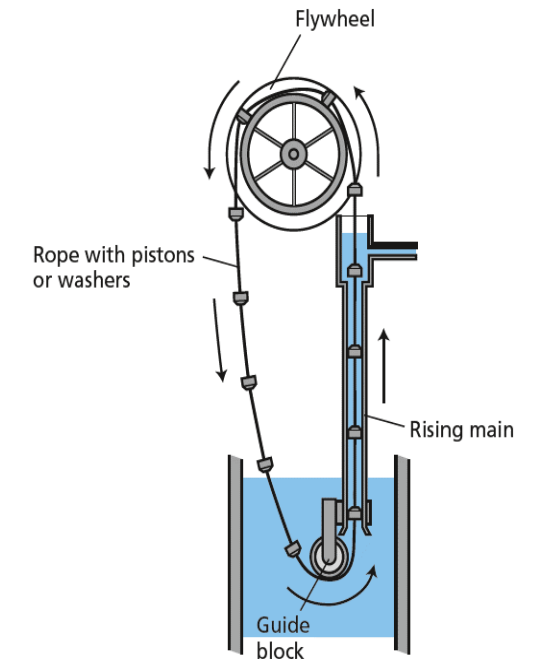
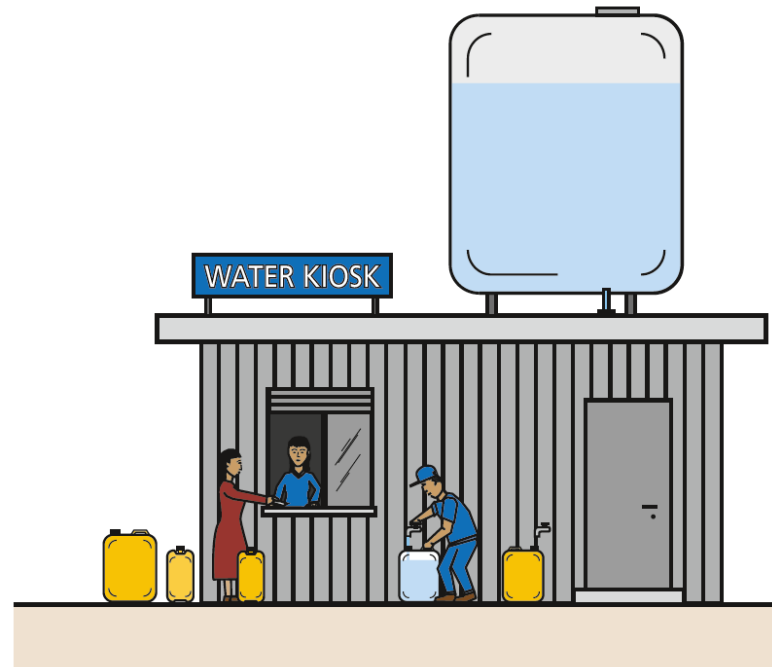
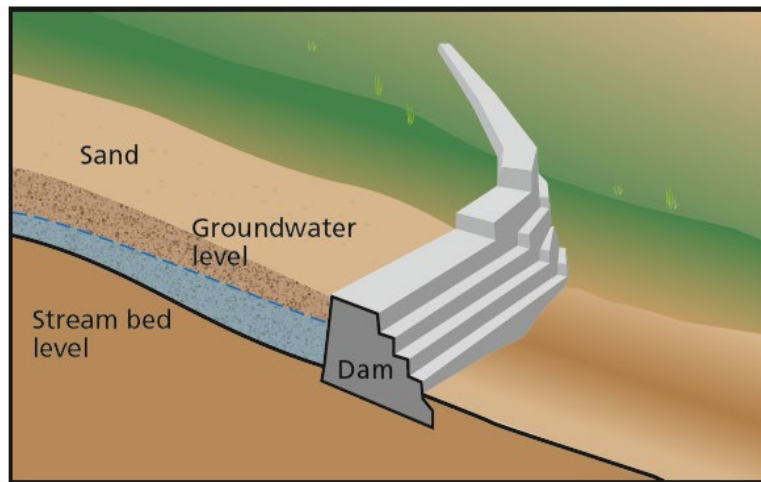

SOURCES

S.1 Rainwater

S.2 Groundwater

S.3 Spring water

S.4 River and stream water

S.5 Ponds, lakes, and dams

S.6 Brackish water, seawater

To establish a water supply system, a resource providing sufficient quantity of water should be available. These systems are commonly based on groundwater or surface water resources, though in areas with sufficient rainfall, rainwater can also be an appropriate water resource. The quantity and quality of the source water determine the required water treatment and water supply system design. Depending on the source, water

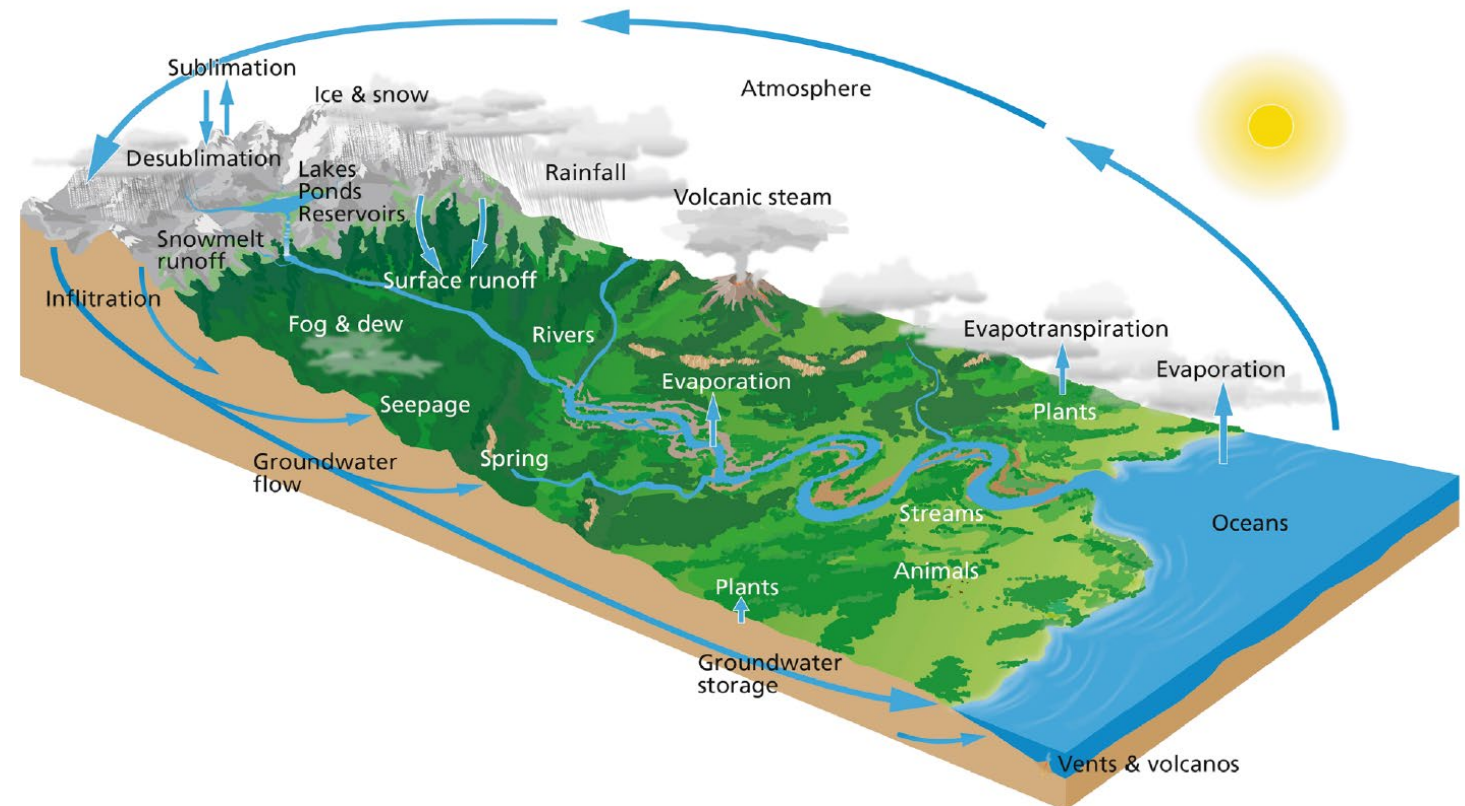

S.1 Rainwater

Applicability:

- Generally good quality but vulnerable to deterioration and algal growth
- Slightly acidic so roofing and storage containers must resist corrosion
- 300 mm/year minimum advised

Health/environmental aspects:

- Lacks minerals, which affects taste
- Odor can develop during storage
- Point of use treatment advised

Advantages/disadvantages:

- ✓ Complements groundwater sources
- ✓ Generally good quality
- Seasonal supply
- Vulnerable to air pollution and deterioration in storage
- Taste/odor problems

Rainwater refers to water that falls in drops from clouds to the earth's surface.

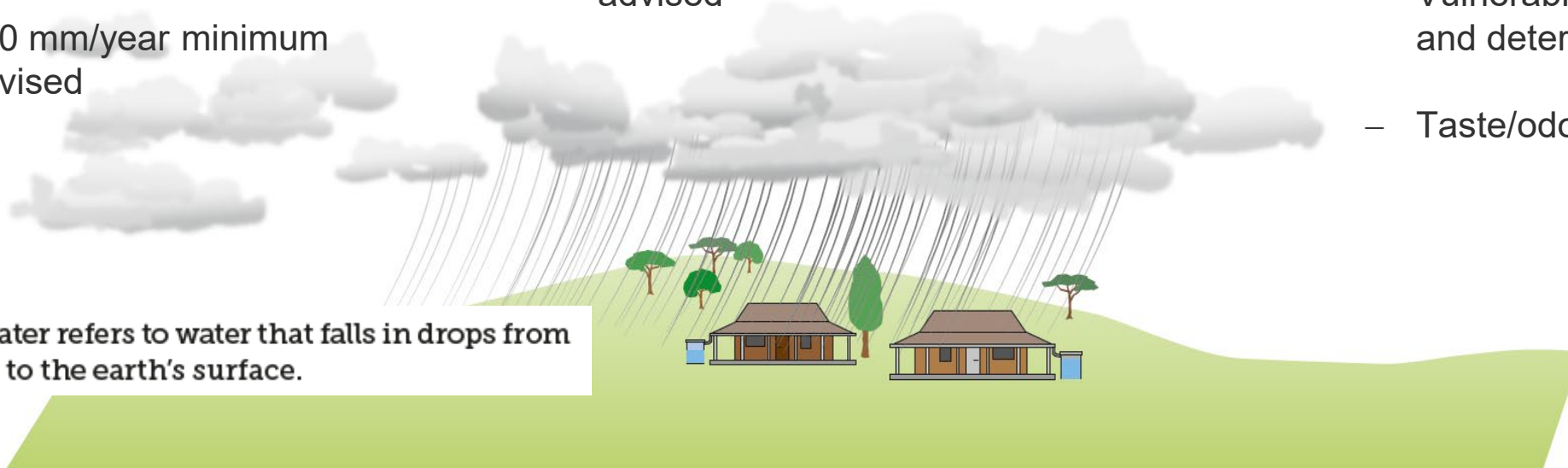

S.2 Groundwater

Applicability:

- Generally accepted by users
- Usually available close to where it is needed
- Extraction rates should not exceed recharge

Health/environmental aspects:

- Filters microbial contaminants (deep aquifers)
- May be naturally contaminated (As, F, Mg, Fe)

Advantages/disadvantages:

- ✓ Generally better quality than surface water
- ✓ Reliable availability
- Treatment might still be required
- Over-extraction problems
- Deep aquifers are expensive to access

Groundwater is fed by rainwater and from surface waters, such as rivers, streams, lakes, or wetlands, which infiltrate into the underground.

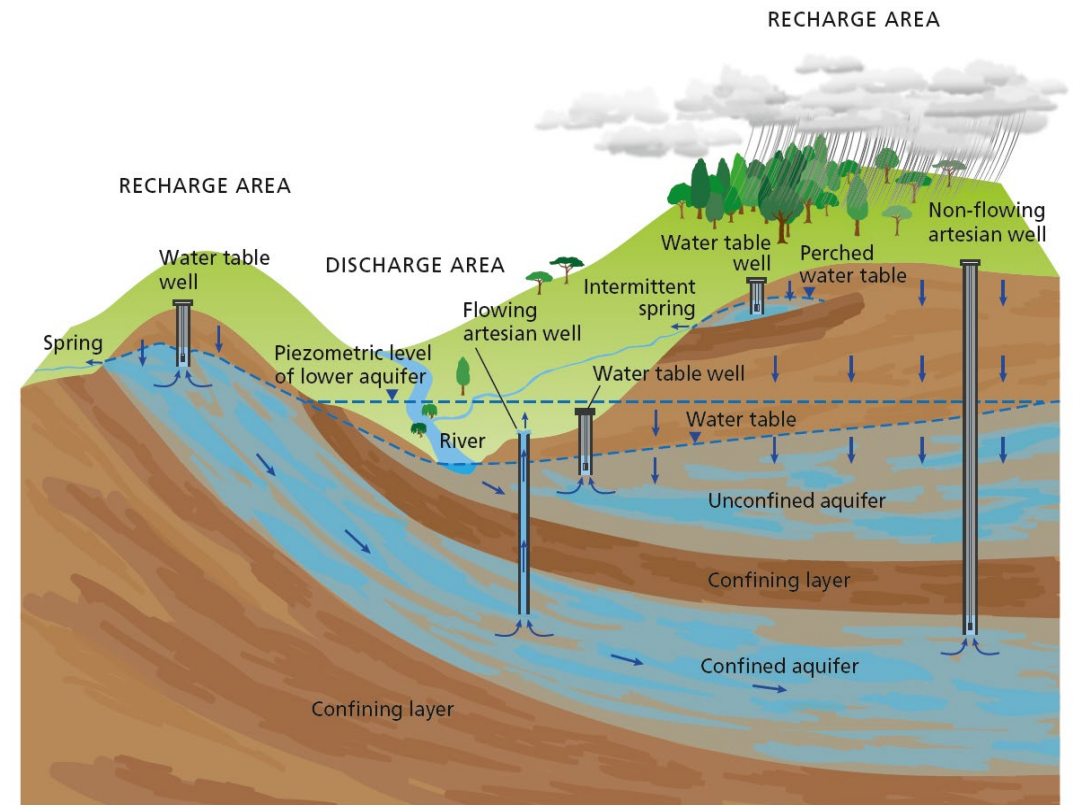

S.3 Spring water

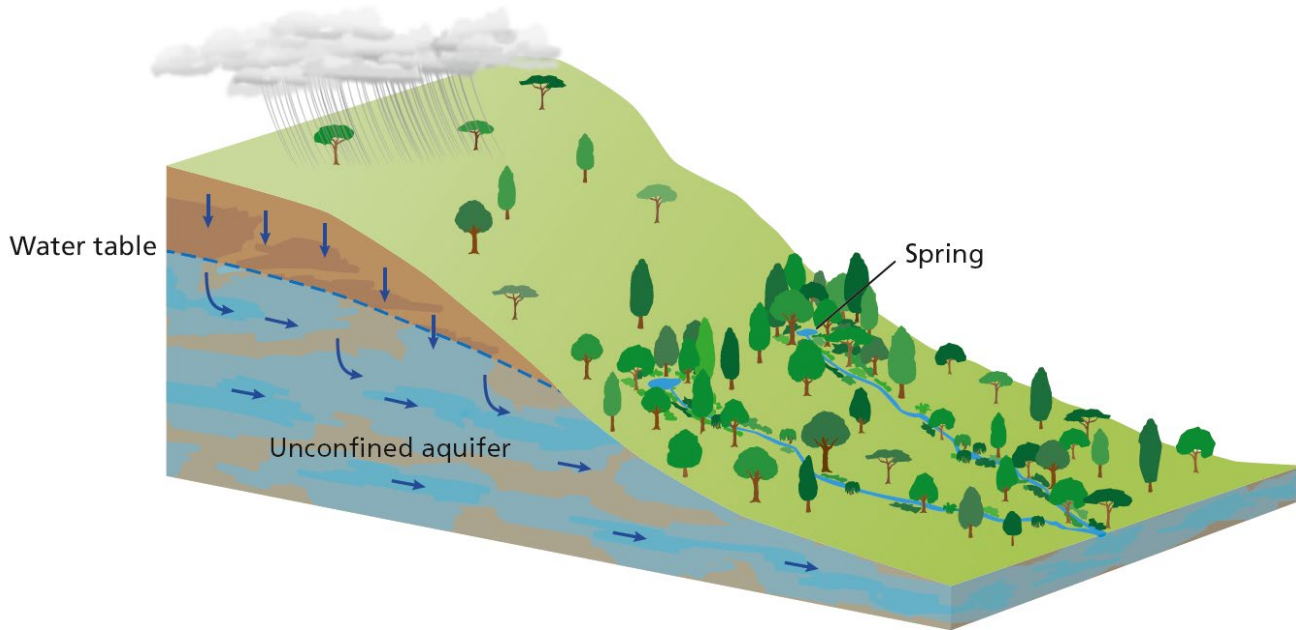

A spring is groundwater naturally flowing from the earth's subsurface to the surface.

Applicability:

- Usually located on hillsides = gravity flow
- Generally preferred by users
- Requires proper tapping and protection to maintain quality and supply

Health/environmental aspects:

- Generally good quality if catchment is protected
- Surface run-off can introduce contamination

Advantages/disadvantages:

- ✓ Good quality source
- ✓ High acceptance
- ✓ Low-cost construction
- Vulnerable to run-off
- Seasonal variation
- May be difficult to access (steep hillside)

Optional viewing

Source selection (10') <https://youtu.be/FvXi6srkeLk>

A description of the criteria to **select a water source**, with the advantages and disadvantages of the main types of water source:

- Surface water (Rivers, lakes and reservoirs)
- Groundwater (springs, wells)
- Rainwater
- Brackish and sea water



INTAKE

I.1 Roof water collection

I.2 Rainwater catchment dam

I.3 Sand/ subsurface dam

I.4 Protected spring intake

I.5 Protected dug wells

I.6 Protected boreholes

I.7 River and lake water intake

I.8 Riverbank filtration

I.9 Seawater intake

In all improved water sources, water is collected from the source through an intake or withdrawal system. For each water source, there are various intake systems available. Some intake systems also act as a reservoir for storing water or provide a certain level of treatment.

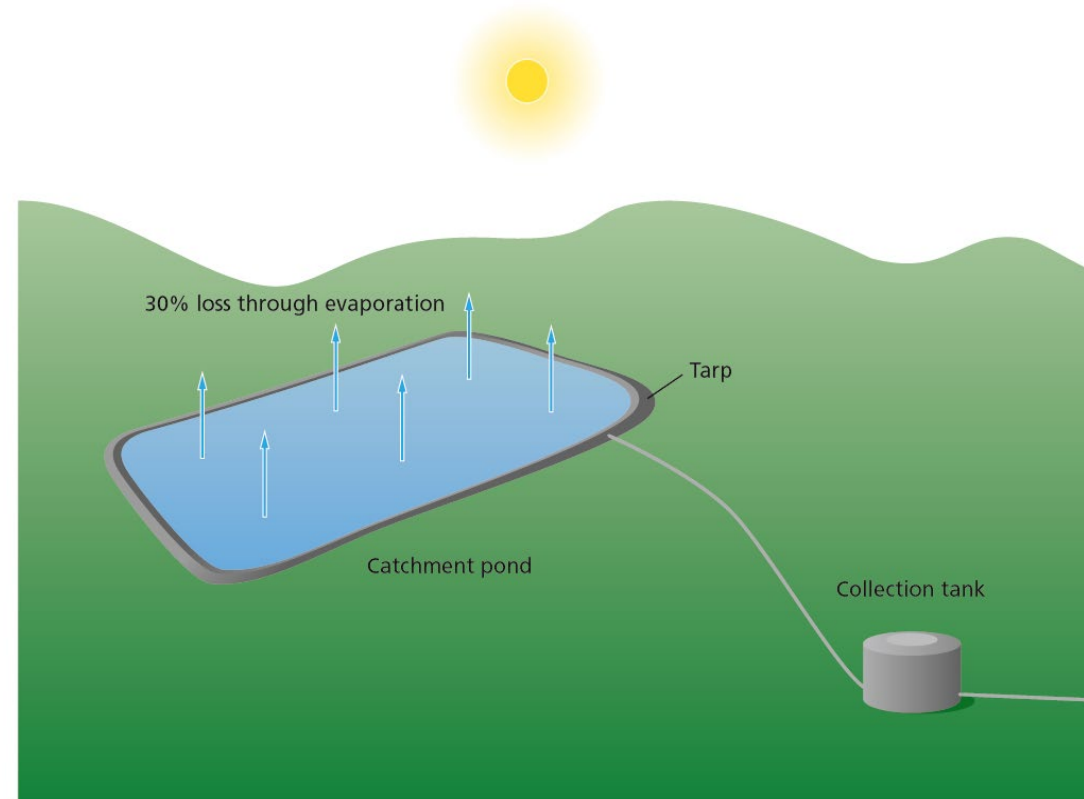

I.1 Roof water collection system

Applicability:

- System sized to rainfall patterns and demand
- Usually a supplement to a household's main water source
- Tank is the most expensive component

Health/environmental aspects:

- Quality dependent on harvesting method
- Roof may collect bird droppings, air particulates
- Contamination and algal growth in tanks

Advantages/disadvantages:

- ✓ Gravity flow
- ✓ Low cost and low maintenance
- ✓ Self-supply
- Low/no availability in dry season
- Contamination may be introduced

Rainwater is collected from a roof by a gutter and stored in a tank. Ideally, it includes a filter box to remove larger pieces of debris and a first flush device to redirect and discharge the first portion of roof run-off water that carries pollutants from the roof surface.

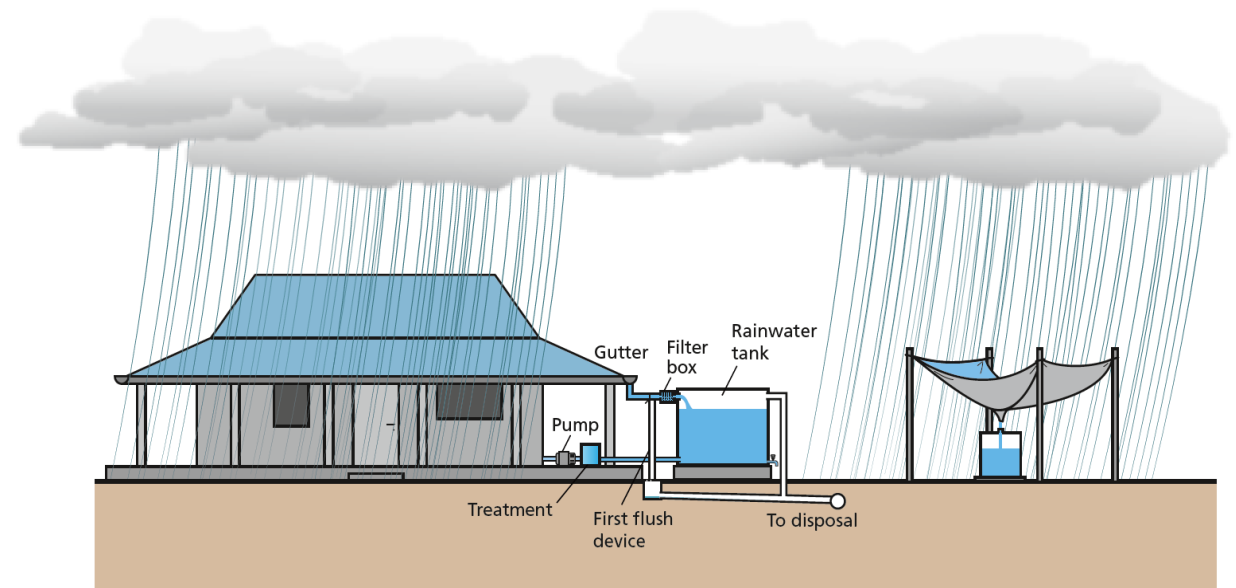

ROOF WATER COLLECTION SYSTEM

TAURPAULING COLLECTION SYSTEM

I.4 Protected spring intake

Spring water collection systems are constructed to catch spring water, facilitate its collection, and protect it from contamination.

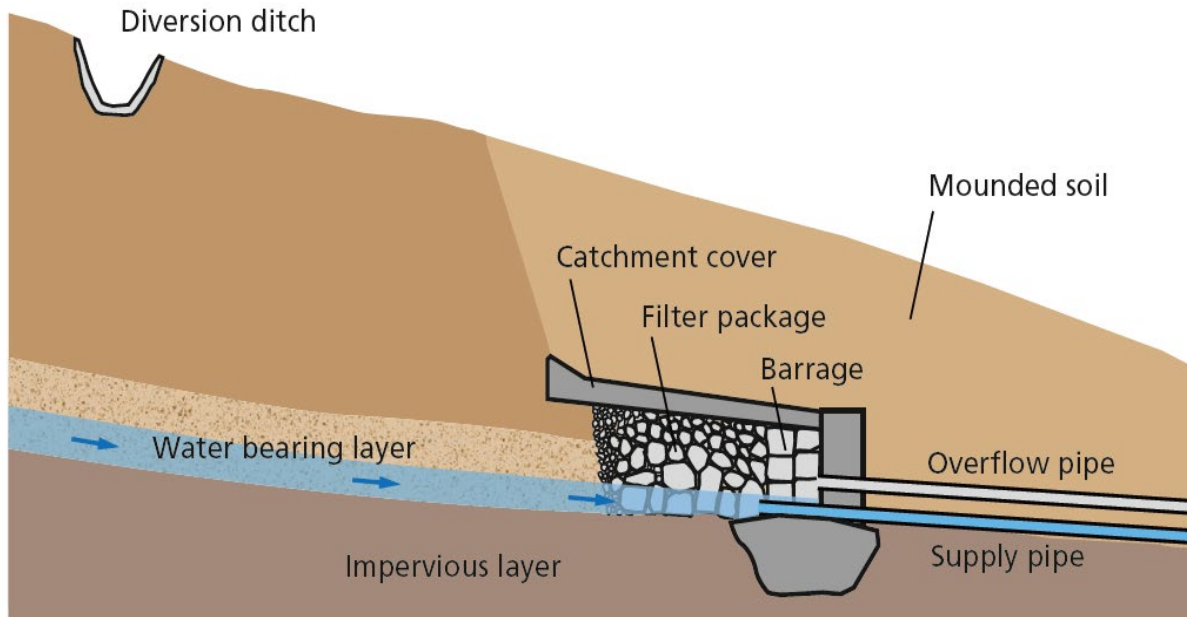

Applicability:

- Can be constructed from local materials
- Adaptable design with one open side
- 15-30 meter protection zone recommended
- Trees/bushes >15 m distance from box

Health/environmental aspects:

- Integrity of structure and protection zone will influence quality
- Spring box can provide sedimentation features

Advantages/disadvantages:

- ✓ Low cost and simple operation/maintenance
- ✓ Adaptable design
- Flow variability
- Erosion issues

I.5 Protected dug wells

Applicability:

- Soil type, diameter and depth determines the amount of water available
- Suitable for high/shallow groundwater tables
- Avoid areas with high run-off or large rocks

Health/environmental aspects:

- Extraction rate must not exceed recharge rate
- Groundwater is generally safer than surface water but can still be contaminated
- Regular chlorine disinfection recommended

Advantages/disadvantages:

- ✓ Low cost and locally available materials
- ✓ High acceptance
- Contamination risks, e.g., naturally occurring As or introduction of fecal bacteria
- Wall collapse risks during construction

A dug well results from excavating a hole in the ground from which groundwater can be abstracted with a pump or a bucket. A dug well is protected from run-off water by a well lining, a platform (apron), and a well cover.

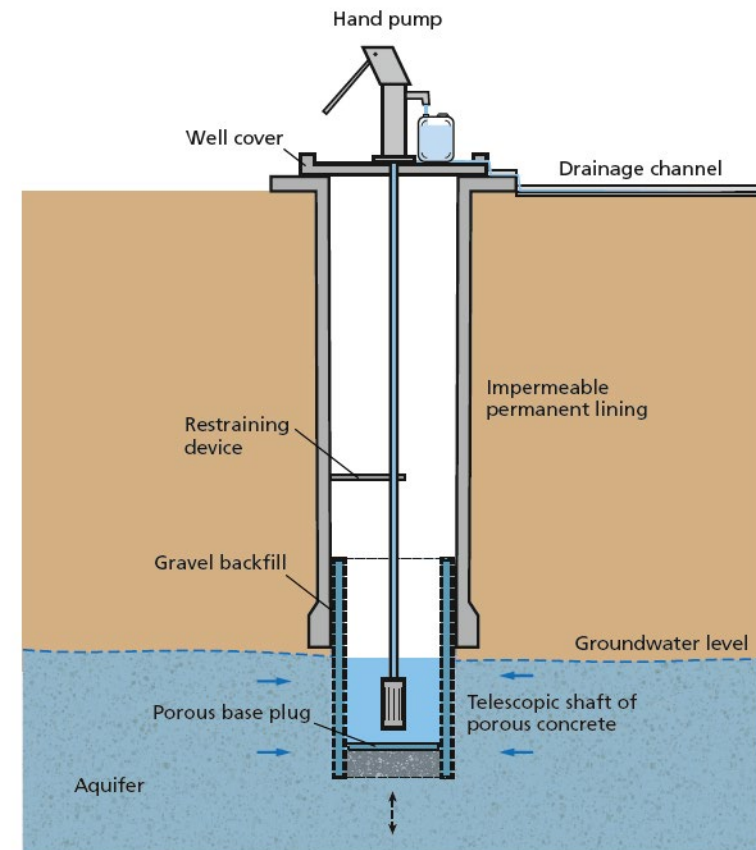

Abstraction entails the capture and removal of raw water from a source and requires the availability of energy for subsequent transportation of the water to treatment plants, storage tanks, or distribution networks.

ABSTRACTION

A.1 Hydraulic ram pump

A.2 Piston/ plunger suction pumps

A.3 Direct action pump

A.4 Piston pump/ deep well pump

A.5 Progressive cavity pump

A.6 Diaphragm pump

A.7 Rope and washer pump

A.8 Radial flow pumps

A.9 Axial flow pumps

A.10 Gravity

A.11 Human powered

A.12 Wind

A.13 Solar

A.14 Electric

A.15 Internal combustion engine

A.4 Piston pump/ deep well pump (positive displacement)

Applicability:

- Generally used as a communal water supply option
- Ideal for deep water tables beyond reach of suction and direct action pumps
- Require skilled repairs and supply chain for replacement parts

Health/environmental aspects:

- Water generally free of microbial contamination
- Labor intensive water collection
- Acidic water can cause corrosion issues (iron, lead leaching)

Advantages/disadvantages:

- ✓ Provides a safe water source where alternatives are unavailable
- Greater maintenance and repair needs
- Exertion due to water fetching

Deep well piston pumps are a type of positive displacement pump, which displaces a fixed amount of water per cycle. Within this category, deep well piston pumps are unique in that water is lifted from deeper depths with the help of additional levers or gears.

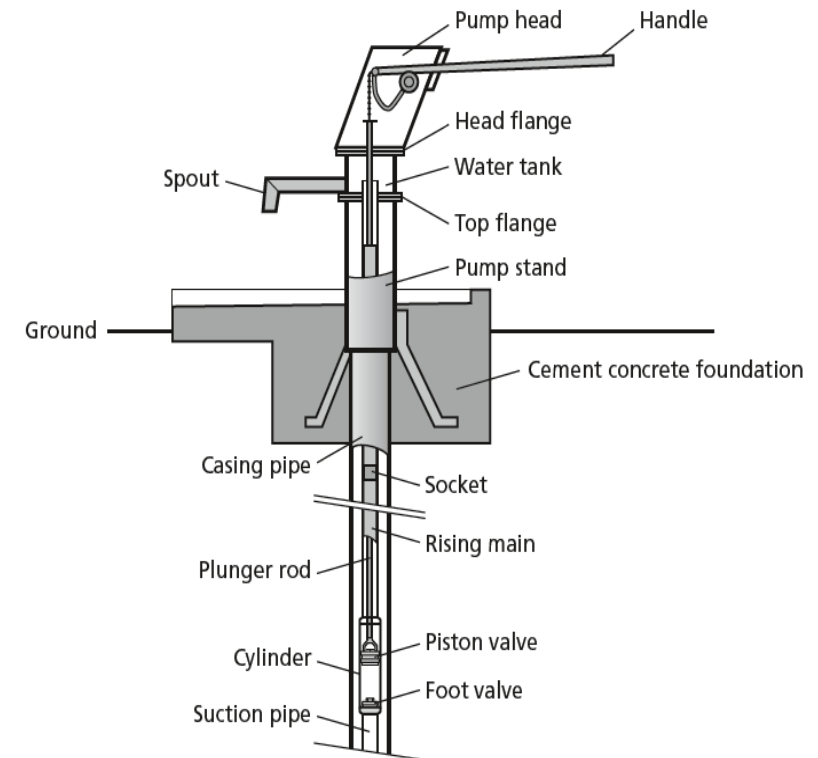

A.7 Rope pump (positive displacement)

Applicability:

- Manual operation < 50 m, motorized <100 m
- Generally installed in dug wells serving households or small community
- Ideal for gardens and other productive uses

Health/environmental aspects:

- Keep slab and components clean/ covered to avoid introducing contamination
- Motorized systems must avoid over-extraction

Advantages/disadvantages:

- ✓ Low cost and simple design
- ✓ Locally available materials
- Limited capacity
- Significant effort to pump manually >5 m
- Contamination can be introduced

Rope pumps are a type of positive displacement pump, which displaces a fixed amount of water per cycle. Within this category, rope pumps (also known as rope and washer pumps) are unique in that water is lifted directly using a continuous movement of a flywheel in only one direction (rather than in a reciprocating manner). The below-ground components are mostly made from plastic, which makes them corrosion resistant and easier to handle.

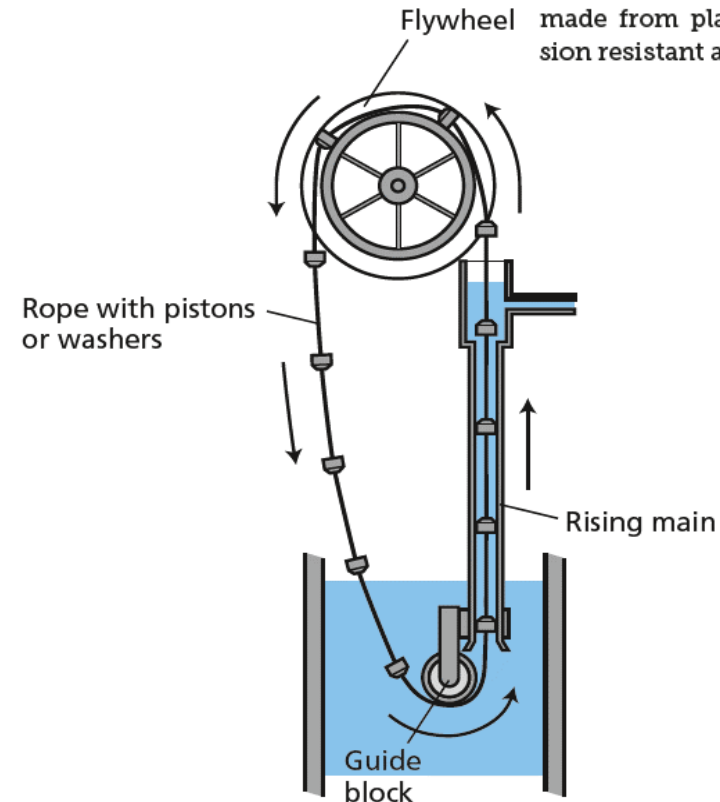

A.10 Gravity (energy source)

Applicability:

- Can be applied to springs, streams, or elevated tanks
- Suitable in areas with topographical variation
- Often high capital cost but low running cost

Health/environmental aspects:

- Clean energy source
- Pipe breakage can deplete source

Advantages/disadvantages:

- ✓ Low total life cycle cost
- ✓ Reliable energy supply
- High initial investment
- Not available to all systems

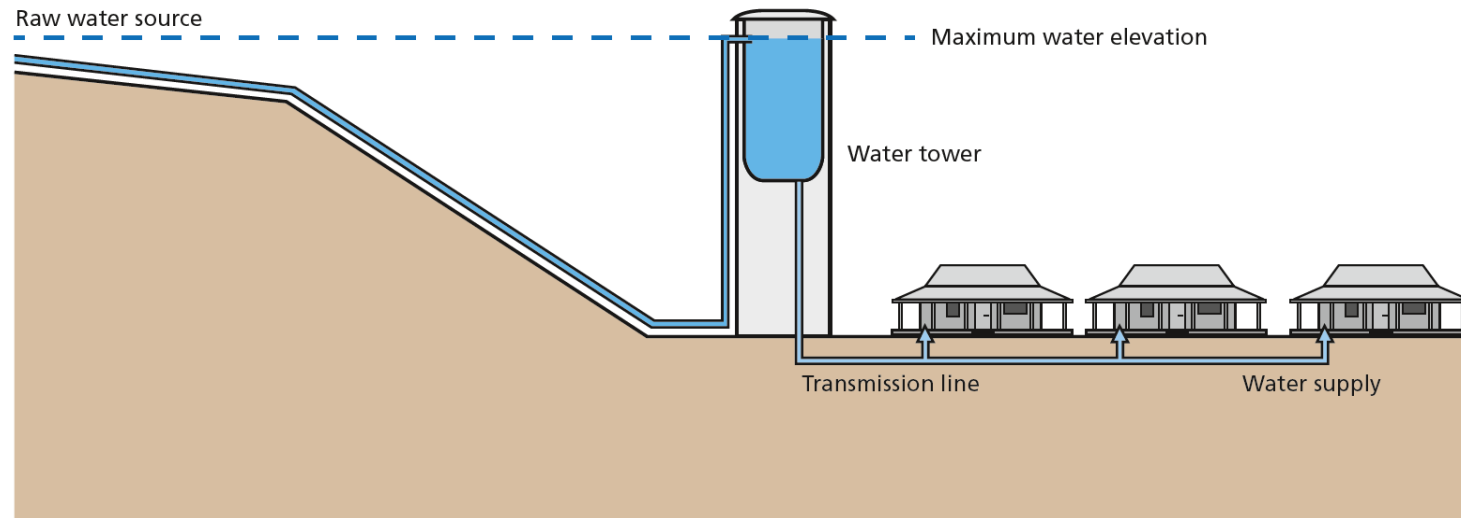

Water transport is often most economical when the force of gravity is used to transport water through pipelines (or channels). As an energy source, the major advantage of using gravity as a driving force to move water is that it is free, so pumps are rarely needed within a gravity system.

A.11 Human powered (energy source)

Applicability:

- Used when other energy sources are unavailable
- Household- or small community-level
- Limited to 70 Watts = < 1 L/s for 10 m lift

Health/environmental aspects:

- Risk of injury or exertion
- Limited capacity for meeting a households daily needs
- Significant time burden

Advantages/disadvantages:

- ✓ “Free” energy source
- ✓ Low carbon emission
- Only limited water supply possible (water is heavy)
- Injury, stress and time burden
- Affects women and girls most

The most basic form of energy available for ensuring a household water supply is the effort that each person can apply.

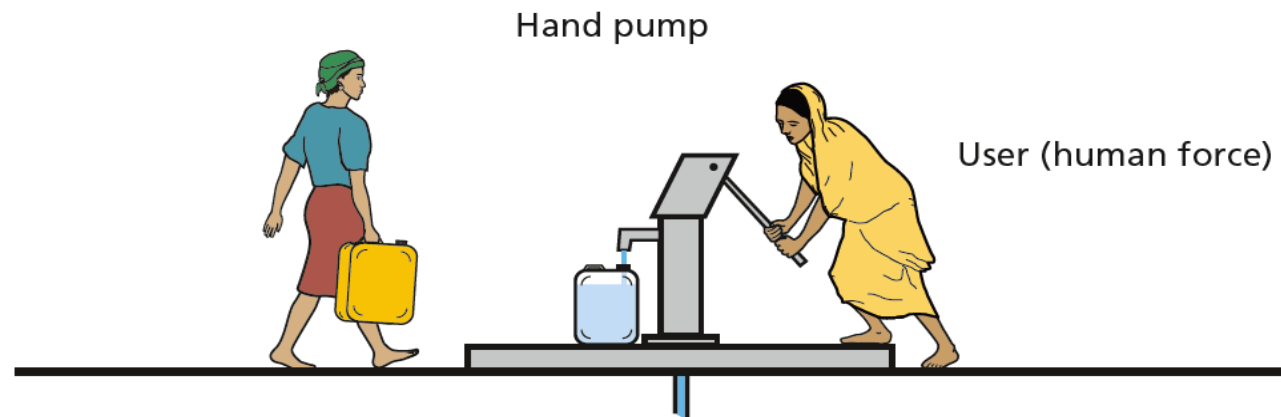

Optional viewing

Intake (8') <https://youtu.be/QaYMbub4ljw>

Abstraction (12') https://youtu.be/bVsMCly11_4

An overview of the **water intake options**, their applicability and limitations.

A detailed overview of **water abstraction options**, to collect water at the source intake system and transport it (to the treatment plant, or storage tank, or distribution network, or consumer).

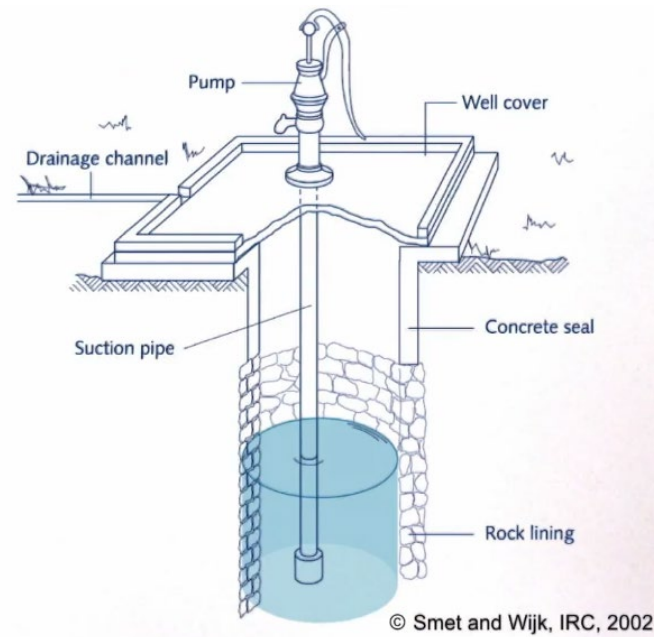

This section describes water treatment technologies that are generally appropriate for larger groups of users. It includes community treatment options, semi-centralized applications in neighborhoods, and centralized-type applications in urban areas. Household water treatment methods are described in section U.

TREATMENT

T.1 Clarification methods

- T.1.1 Roughing filtration
- T.1.2 Rapid sand filtration
- T.1.3 Microfiltration
- T.1.4 Coagulation/ flocculation/ sedimentation
- T.1.5 Coagulation/ flocculation/ filtration

T.2 Removal/ inactivation of microorganisms

- T.2.1 Chlorination
- T.2.2 On-site electrochlorination
- T.2.3 UV disinfection
- T.2.4 Slow sand filtration
- T.2.4 Ultrafiltration
- T.2.5 Pasteurization

T.3 Treatments for geogenic contaminants

- T.3.1 Fluoride removal methods
- T.3.2 Arsenic removal methods

T.4 Treatments for organic and inorganic contaminants

- T.4.1 Activated carbon
- T.4.2 Ozonation
- T.4.3 Nanofiltration

T.5 Desalination (salt removal)

- T.5.1 Membrane distillation
- T.5.2 Reverse osmosis

T.2.1 Chlorination

Applicability:

- Most common disinfection method worldwide
- Applied from centralized to household scale
- Requires low turbidity (< 5 NTU) and pH of 6.5 – 8.0

Health/environmental aspects:

- Skin/eye contact risks
- Safe handling and dosing requires training
- Important to minimize the formation of disinfection byproducts

Advantages/disadvantages:

- ✓ Low cost and widely available
- ✓ Reliable for inactivating bacteria and most viruses
- Ineffective against protozoa and some viruses
- Taste/odor acceptance thresholds vary

Chlorination consists of the addition of chlorine compounds to water. Under optimal conditions, chlorine inactivates bacteria and many viruses and provides residual protection that minimizes the risk of microbial re-growth and recontamination.

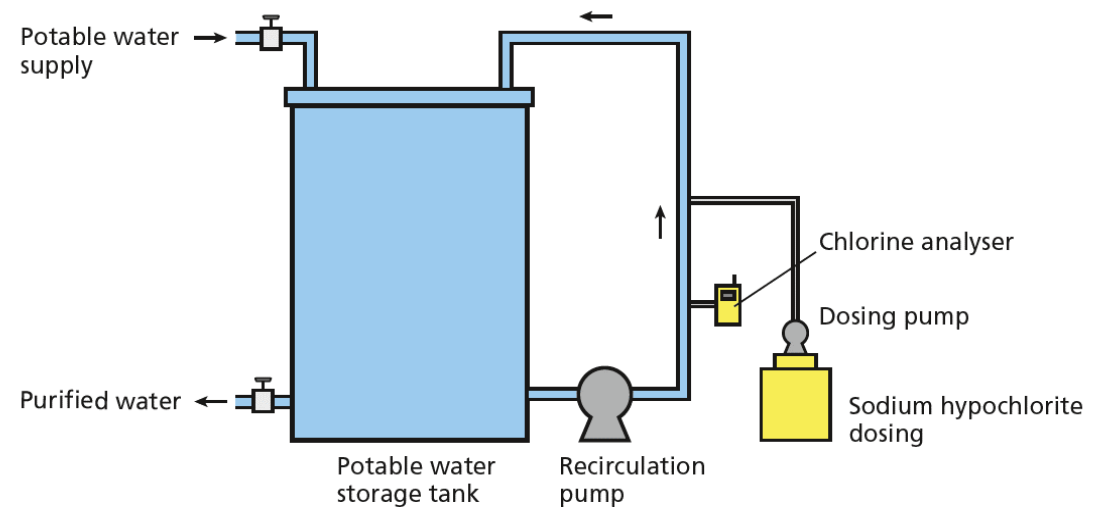

T.2.4 Slow sand filtration

Applicability:

- Low turbidity raw water (<10 NTU)
- Incompatible with chlorination due to biolayer
- Can be operated using gravity or pump
- Ideal for small community or municipal supply

Health/environmental aspects:

- Acceptance challenges
- Requires considerable space
- Filtered water susceptible to recontamination

Advantages/disadvantages:

- ✓ No chemicals or pumps required
- ✓ Constructed with local materials
- ✓ Easy to operate, long lifespan
- Large footprint
- Clogs easily

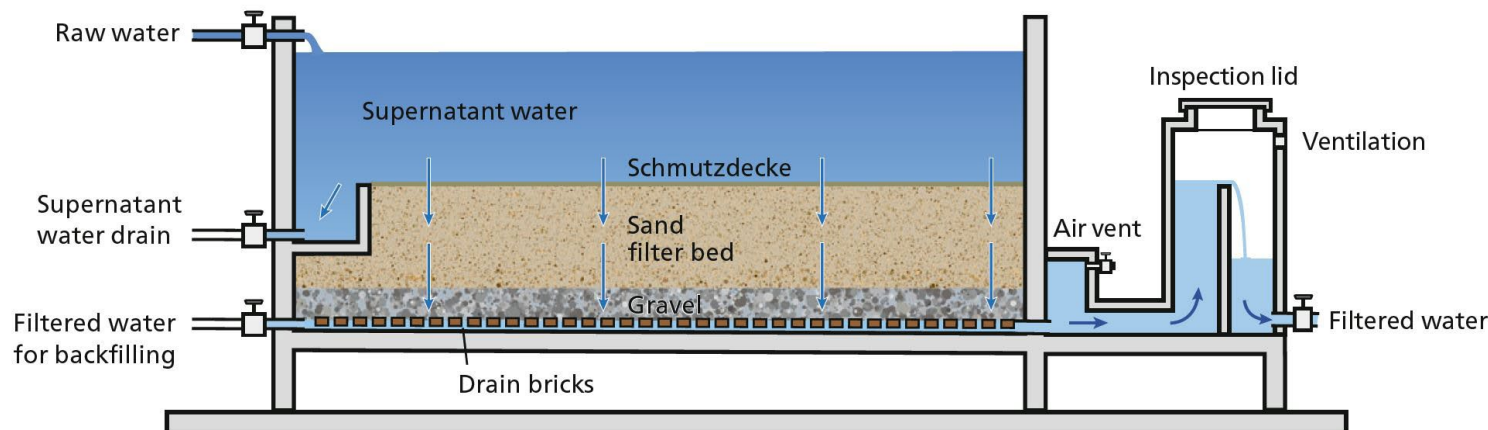

Slow sand filters (SSF) remove suspended and colloidal solids from turbid water. This process is characterized by a biologically active upper layer (Schmutzdecke) that forms during filtration and that supports the removal of pathogenic microorganisms (bacteria, protozoa, and viruses). To support this biological activity, a slow water flow rate of about 0.1–0.3 m/h is required. SSF also require a low inflow turbidity (< 10 NTU) to prevent clogging.

Optional viewing

Water Treatment (14') <https://youtu.be/IAE7YKK0TkA>

A description of the criteria for **selecting water treatment technologies**, with the advantages and disadvantages of the main categories of treatment:

- Clarification methods
- Removal of microorganisms
- Treatments of geogenic contaminants
- Treatments of organic and inorganic contaminants
- Desalination



3.5 Water Treatment
Learning objectives

Press **Esc** to exit full screen

ICRC eawag ESCOLE POLYTECHNIQUE FEDERALE DE LAUSANNE

- Get familiar with different drinking water treatment technologies and processes
- Understand major advantages and limitations of the drinking water technologies

0:11 / 14:14

DISTRIBUTION AND TRANSPORT

D.1 Jerry cans

D.2 Water vendors (carts and trucks)

D.3 Water kiosks

D.4 Small public and community distribution systems

D.5 Centralized distribution systems

D.6 Storage tanks and reservoirs

This section describes the technologies or solutions used to deliver water from the source, pumping station, or water-treatment plant to the home of the consumer. They are either privately adopted solutions (D.1 – D.3) or distribution systems with different levels and types of connections (D.4 – D.6).

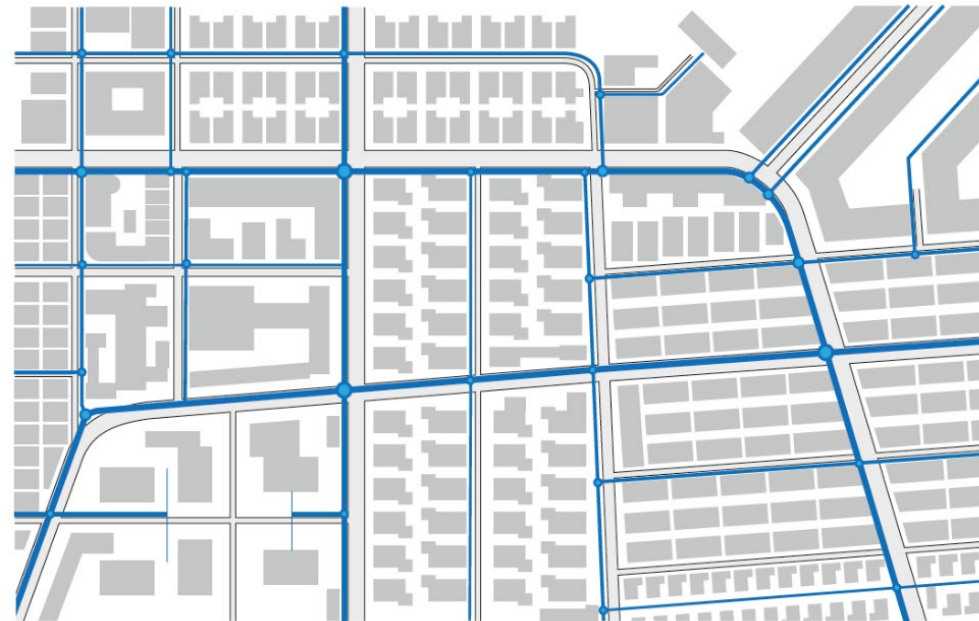

D.1 Jerry cans

Applicability:

- Typically 20 L, carried by person, cart or donkey
- Carrying time should not exceed 30 min / day
- Required in areas where other distribution options to the home are not yet available

Health/environmental aspects:

- Can be contaminated if used with unsafe sources
- Regular cleaning and proper sealing will maintain quality / reduce algal growth

Advantages/disadvantages:

- ✓ Widely available and low cost
- ✓ Adaptable volume
- Recontamination risks
- Time/labor burden, especially for women/girls
- Inadequate volume for certain needs (hygiene, productive activities)

Jerry cans are light plastic containers that can be carried by one person. They can be sealed with a lid to prevent water contamination and are frequently used to carry water home from the source.



D.4 Small public and community distribution systems

Water distribution systems transport water from the water source or water treatment plant to the point where it is delivered or used, such as a community standpipe, yard connection, or household connection.

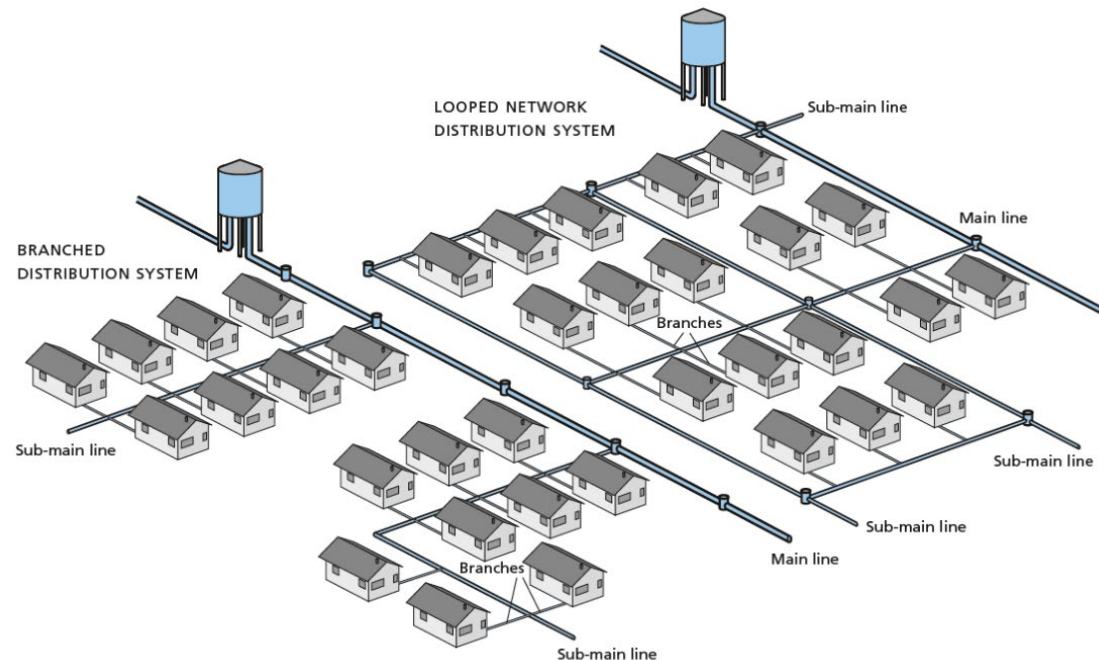

Applicability:

- Pressure head of 5-10 m to prevent ingress
- May be branched or looped (grid) design
- Water delivered to the house, yard or community stand (< 30 min walk)

Health/environmental aspects:

- Water available closer to the home increase consumption
- Must consider disposal of black/gray water

Advantages/disadvantages:

- ✓ Most convenient and desirable option for users
- ✓ Better quality if centrally treated
- Intermittency can introduce contamination
- Higher capital and running costs
- Maintenance and repairs can be complex

USER SAFETY

U.1 Safe water storage

U.2 Ceramic filtration

U.3 Ultrafiltration

U.4 Chemical disinfection

U.5 Boiling

U.6 Pasteurization

This section describes household water treatment and safe storage technologies that can be used as single-stage water treatment alternatives when centralized or community-scale treatment are not available or the quality of the water supply is inadequate. When water contamination occurs during transport between the public tap or water source and home, household water treatment can improve the situation. Drinking water should be stored safely in all cases.

U.7 Biosand filtration

U.8 UV light disinfection

U.9 Solar water disinfection

U.10 Fluoride removal filters

U.11 Arsenic removal filters

U.1 Safe water storage

Applicability:

- May be filled manually or by gravity / pumps
- Required for all cases where continuous safe supply is unavailable
- Volume fitted to source and household demand

Health/environmental aspects:

- Additional connections pose contamination risks, backflow valves needed
- Metal tanks require non-corrosive lining
- Regular cleaning required

Advantages/disadvantages:

- ✓ Reduces recontamination
- ✓ Improves reliability of supply
- Large containers are expensive
- Additional time/ management burden compared to continuous in-house tap

Safe water storage uses containers that protect water from recontamination. The containers can be of various sizes (from 5 L bottles or pots to 1000 L water storage tanks to 5000 L containers on top of buildings) and are characterized by two main features: 1) the presence of a good cover and narrow opening for filling, and 2) the availability of a tap/spigot or connection to the in-house distribution network.

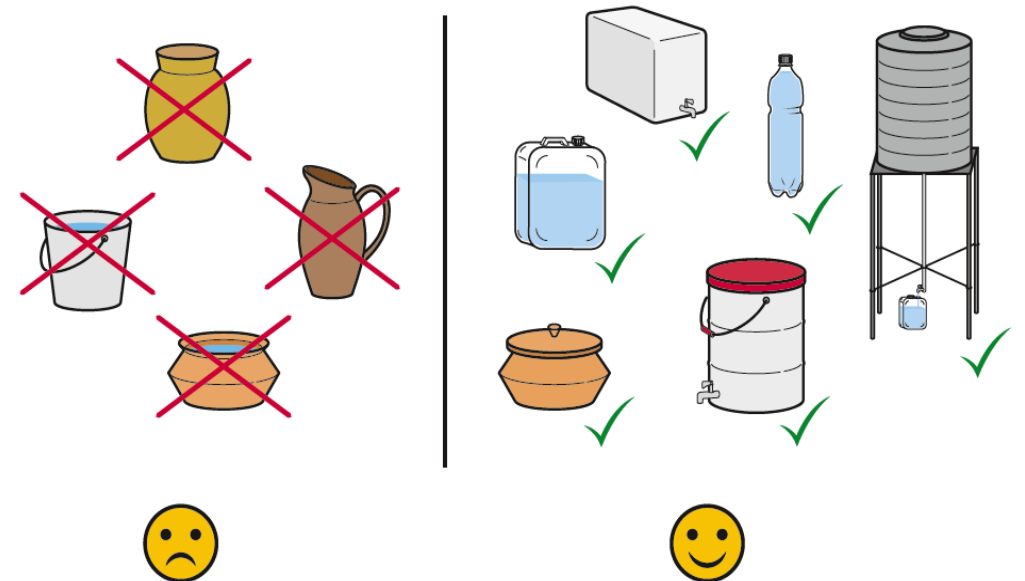

U.2 Ceramic filtration

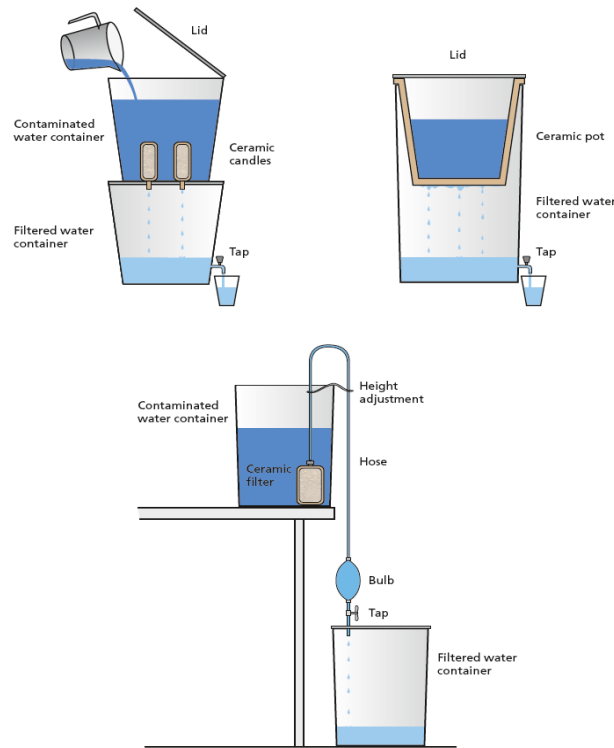

Ceramic filters are simple devices that use pots or candles made out of clay to filter drinking water to remove turbidity and pathogenic microorganisms.

Applicability:

- Suitable for small households
- Requires low turbidity (< 5 NTU) raw water
- Requires supply chain for replacement parts
- Local production possible

Health/environmental aspects:

- Should be paired with safe storage and disinfection
- Good removal of bacteria and protozoa, moderate/low removal of virus

Advantages/disadvantages:

- ✓ High user acceptance
- ✓ Simple to operate and maintain
- Variable treatment effectiveness
- Limited flow rate
- Breaks easily
- Limited affordability

Optional viewing

Distribution, transport and user safety (10')

<https://youtu.be/qnoF7QLIPYQ>

An overview of the **distribution options** for water (in terms of possibility, costs, safety, convenience, complexity,...), and **user safety**.



Part 2

Water System Design

Water System Design

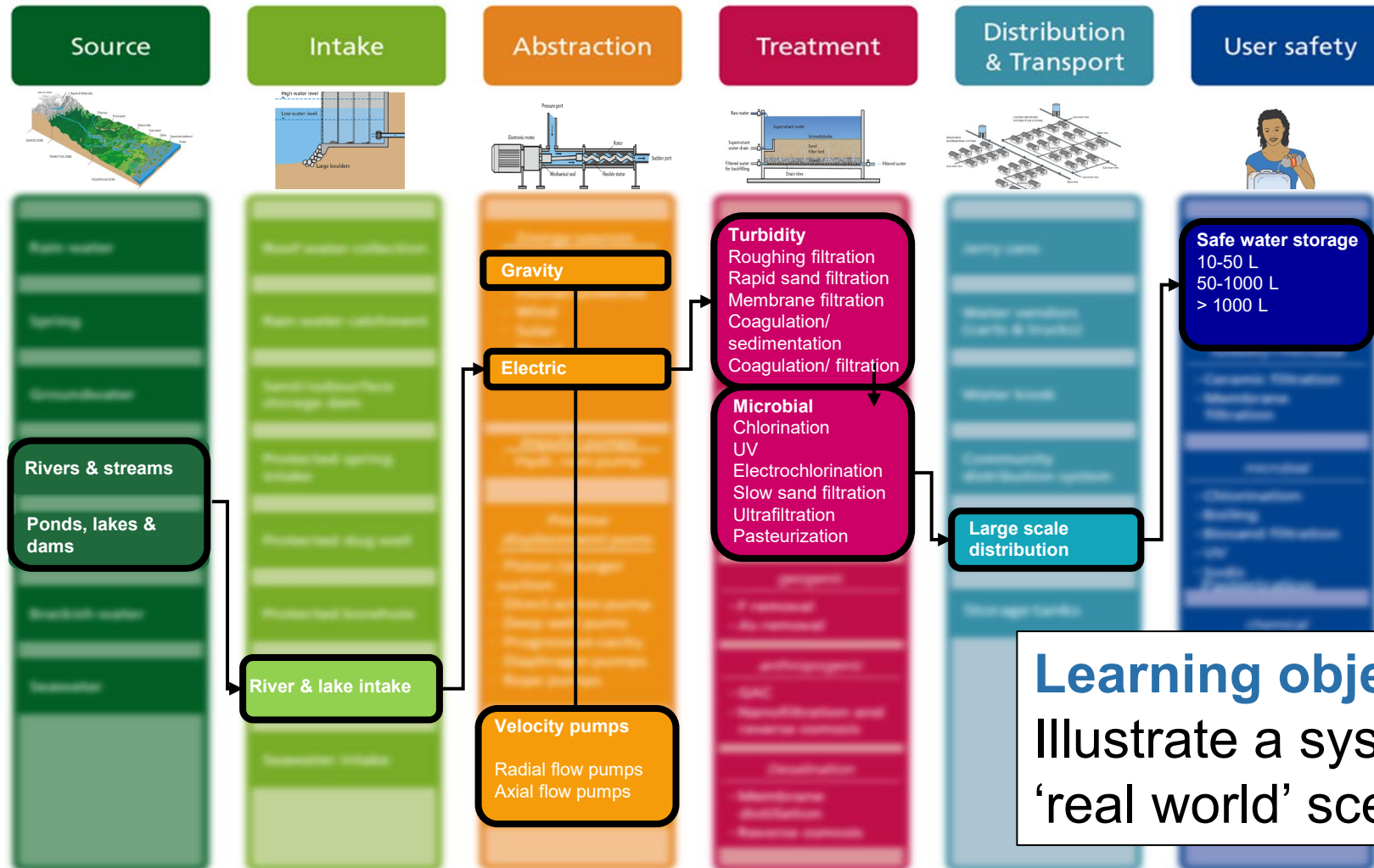

Learning objective 4:
Illustrate a system template for a 'real world' scenario

Design consideration: Source suitability

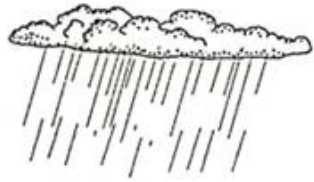

Rainwater

Microbiological quality good
Contains few minerals
Utilisation easy
Storage necessary

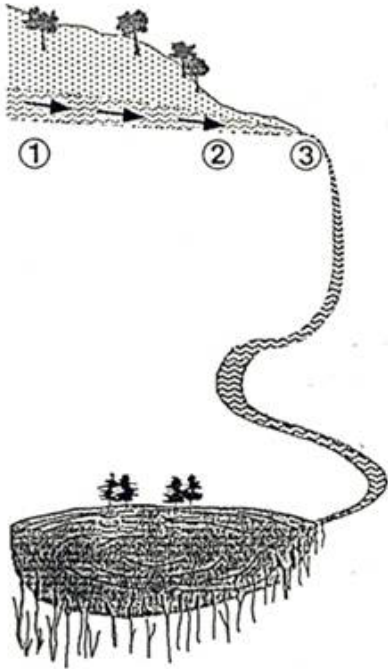

Ground water

Microbiological quality good
Risk of geogenic contamination
Contamination possible for (2) & (3)
Usually no treatment necessary
Utilisation easy (3) => difficult (1)

Surface water

Great risk for microbiological contamination
High content of solids and algi
Treatment necessary

Criteria for selecting a source

1. Quantity of water the source can provide

Immediate capacity & Reliability over time (dry season)

2. Quality of water

Present quality & Risk of pollution

3. Technology required for exploitation:

Type of technology required (cost and technical requirements for installation & maintenance)

Social acceptance

4. Accessibility

Geographical, Social, Financial, Security

Design consideration: Treatment needs

Avoid treatment (source!)

- High investment and maintenance cost
- Availability of spare parts & chemical difficult
- Lack of trained personnel

Goal

- Utilisation of water with low health risk → ground water and spring water
- Protection of the water source
- No treatment necessary is the best treatment

Treatment Parameters

- Microbiological contamination
- Turbidity (silt, clay, algi)
- Geogenic contaminants: Arsenic, Fluoride, Iron, Manganese
- Antropogenic chemicals

Addressing different quality issues

Quality issue	Examples of suitable technologies
Turbidity	
Surface Water	Flocculation, Sedimentation Roughing & Slow Sand Filtration
Desalination	
Saline, backish groundwater, sea water	Reverse osmosis (RO), Distillation
Removing chemical contamination	
Fluoride: Groundwater	Adsorption to activated alumina or bone char, RO
Arsenic: Groundwater	Oxidation, adsorption & ion exchange, RO, Distillation
Anthropogenic pollution: Surface water	Reverse Osmosis, Distillation
Removing microbiological contamination	
Contaminated surface water, groundwater, rainwater	Slow sand filtration, chlorination, UV, ultrafiltration, pasteurization

Additional design considerations

1. **No treatment is the best treatment** – use the water source with highest quality
2. **Water transport distance** is the main usage criteria of a water source – new water points must thus be closer than existing ones, otherwise they will not be used.
3. **Gravity systems** are more appropriate than systems requiring electrical pumps.
4. **Keep supply networks simple**, guarantee frequent controls and maintenance to minimize water losses.
5. **Public taps** are the interface between water supply and user – keep them user-friendly and robust.
6. **Household storage** is needed if water is collected away from the home or if the piped supply is intermittent

Group exercise

A **small town** in western Uganda has about 25'000 people, receives **rain** for three months out of the year and has **easily accessible groundwater**. The town has an **urbanized core**, while the surrounding outskirts are more **rural** in nature. In addition to **households**, there are **two schools**, a **clinic** and several **small businesses**.

1. Propose a possible water supply delivery configuration in the figure to the right.
2. Explain why this is the best configuration for the setting.

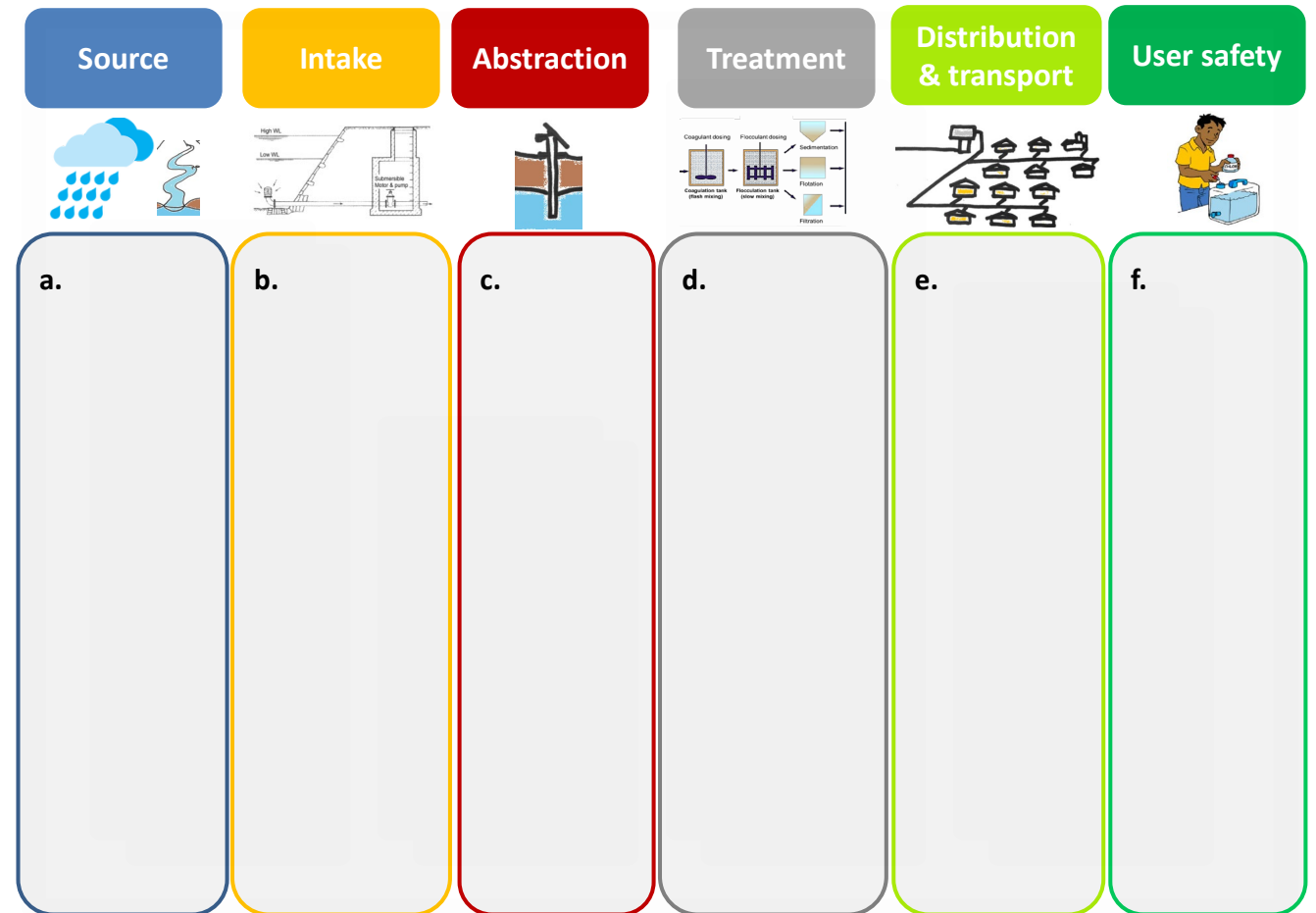

Group exercise

A **small town** in western Uganda has about 25'000 people, receives **rain** for three months out of the year and has **easily accessible groundwater**. The town has an **urbanized core**, while the surrounding outskirts are more **rural** in nature. In addition to **households**, there are **two schools**, a **clinic** and several **small businesses**.

1. Propose a possible water supply delivery configuration in the figure to the right.
2. Explain why this is the best configuration for the setting.

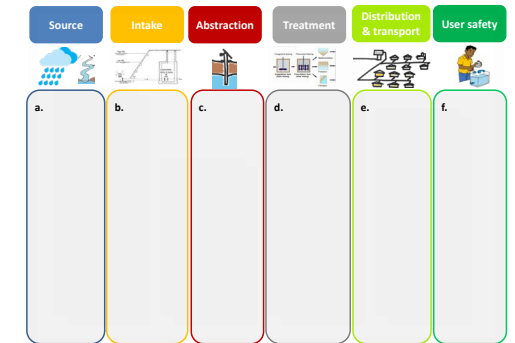

Source



Intake

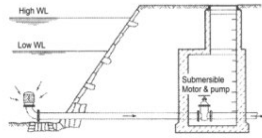

Abstraction



Treatment

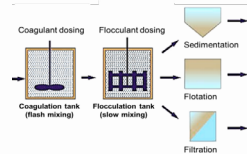

Distribution & transport



User safety



a.

b.

c.

d.

e.

f.

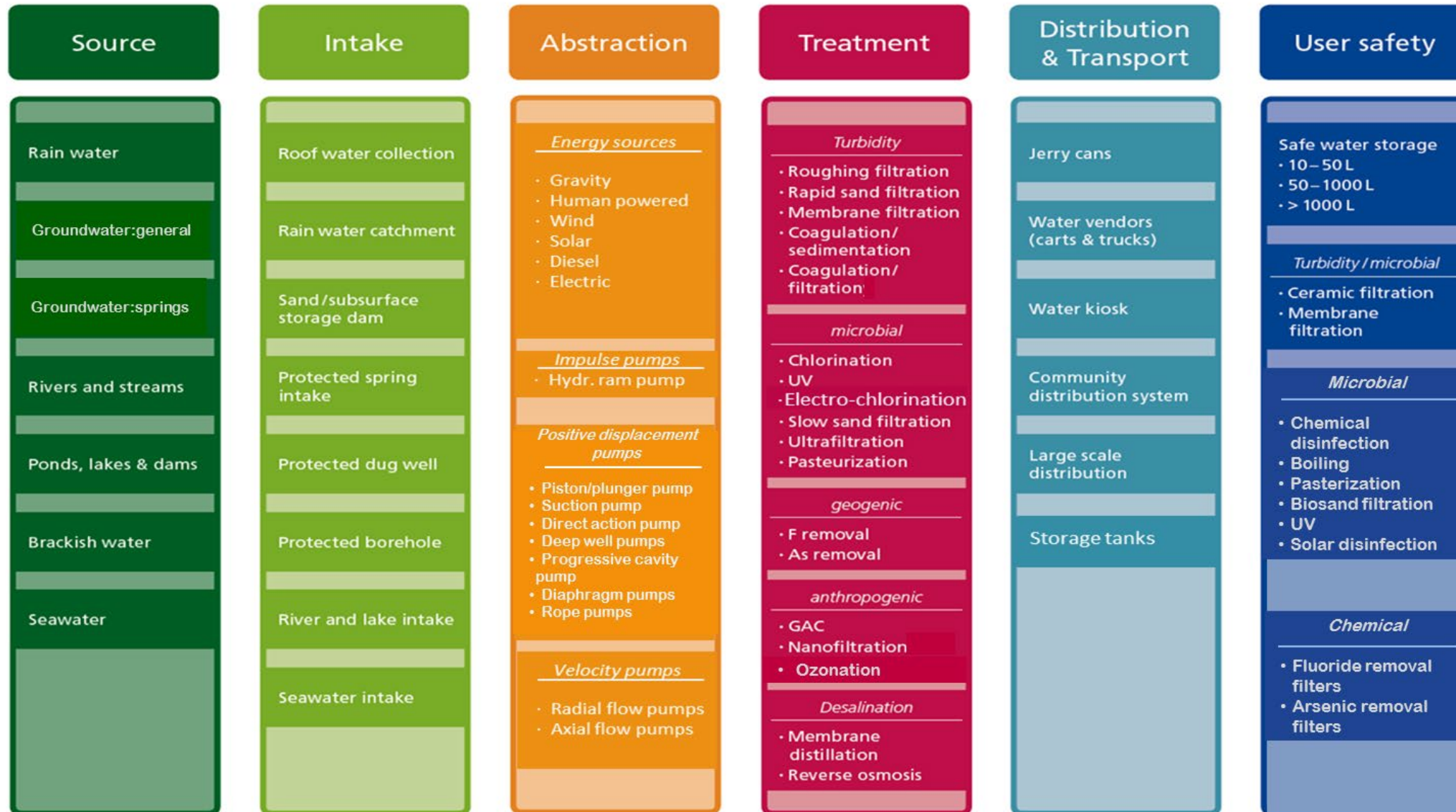

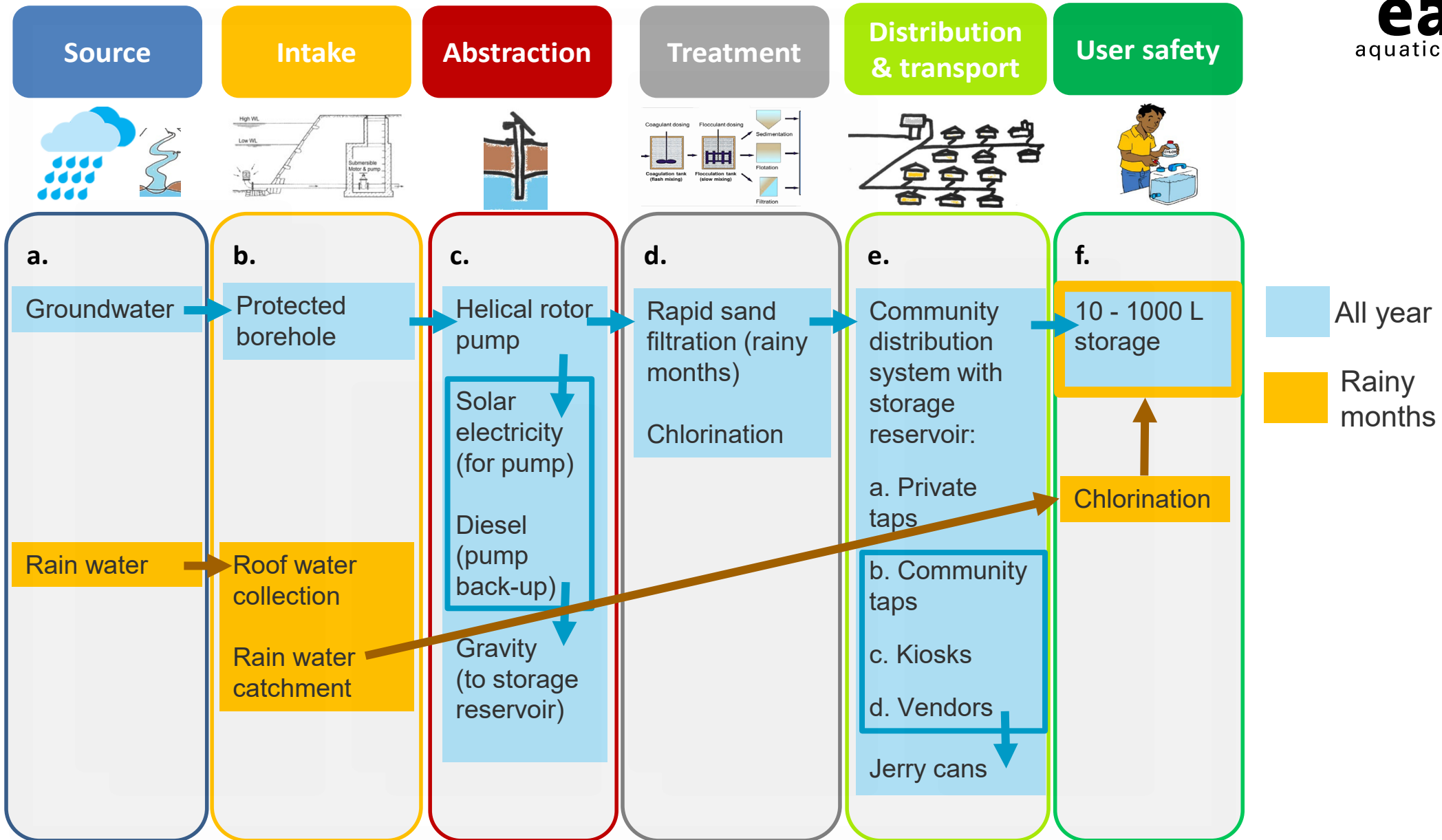

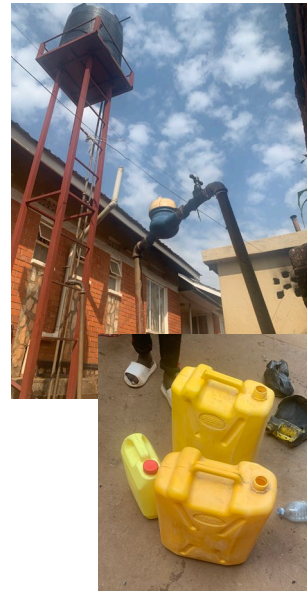

All year
 Rainy months



Internships and MSc projects at Sandec

Email Caterina.DallaTorre@eawag.ch

